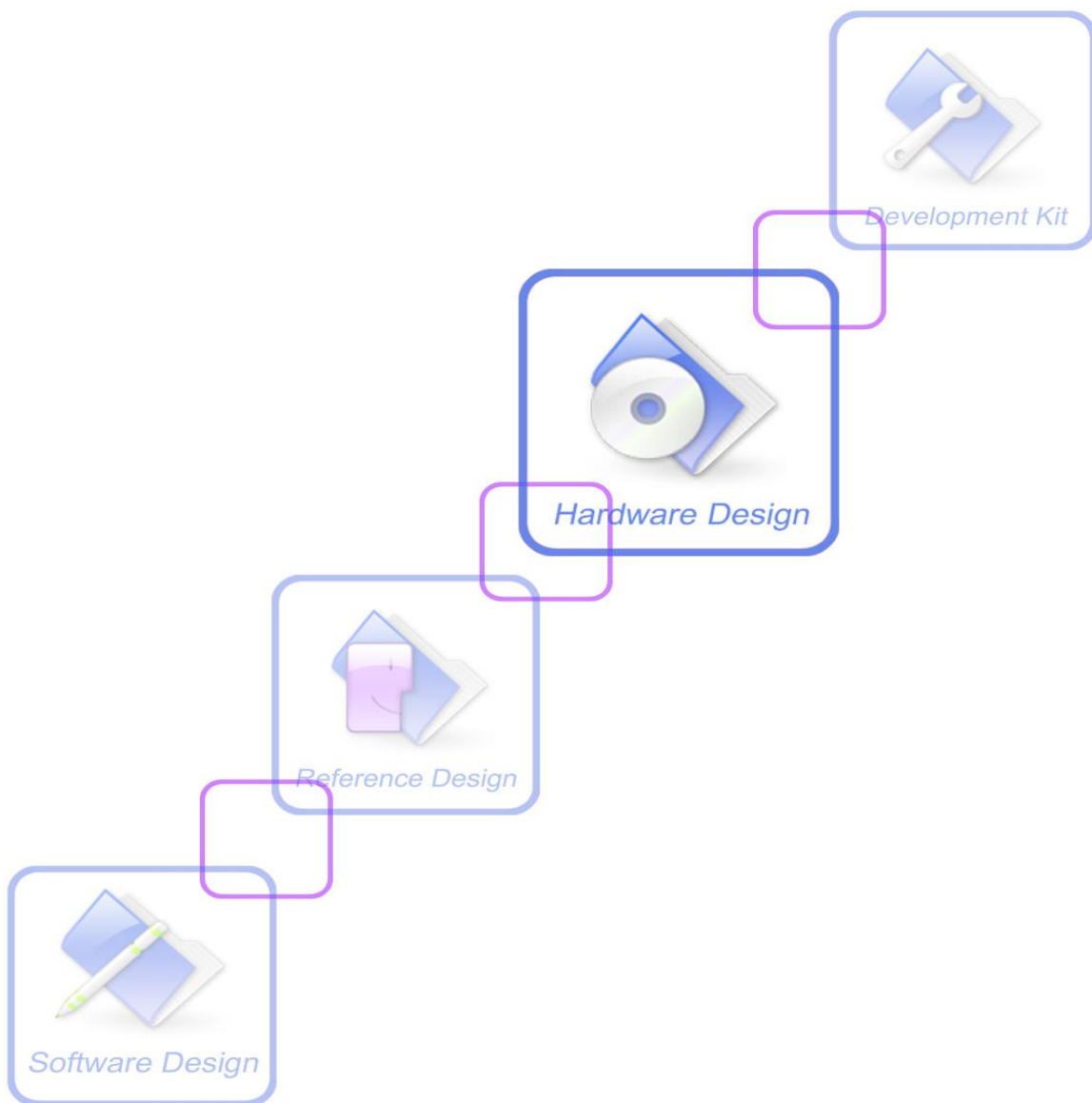




A company of SIM Tech

# SIM800A\_Hardware Design\_V1.02



<b>Document Title</b>	SIM800A Hardware Design
<b>Version</b>	1.02
<b>Date</b>	2016-06-30
<b>Status</b>	Release
<b>Document Control ID</b>	SIM800A_Hardware Design_V1.02

### **General Notes**

SIMCom offers this information as a service to its customers, to support application and engineering efforts that use the products designed by SIMCom. The information provided is based upon requirements specifically provided to SIMCom by the customers. SIMCom has not undertaken any independent search for additional relevant information, including any information that may be in the customer's possession. Furthermore, system validation of this product designed by SIMCom within a larger electronic system remains the responsibility of the customer or the customer's system integrator. All specifications supplied herein are subject to change.

### **Copyright**

This document contains proprietary technical information which is the property of SIMCom Limited, copying of this document and giving it to others and the using or communication of the contents thereof are forbidden without express authority. Offenders are liable to the payment of damages. All rights are reserved in the event of grant of a patent or the registration of a utility model or design. All specification supplied herein are subject to change without notice at any time.

*Copyright © Shanghai SIMCom Wireless Solutions Ltd. 2016*

# Contents

<b>1</b>	<b>Introduction.....</b>	<b>10</b>
<b>2</b>	<b>SIM800A Overview.....</b>	<b>10</b>
2.1	SIM800A Key Features .....	10
2.2	Operating Modes .....	12
2.3	SIM800A Functional Diagram .....	13
<b>3</b>	<b>Package Information .....</b>	<b>14</b>
3.1	Pin out Diagram.....	14
3.2	Pin Description .....	15
3.3	Package Dimensions.....	17
<b>4</b>	<b>Application Interface.....</b>	<b>19</b>
4.1	Power Supply.....	19
4.1.1	Power Supply Pins .....	21
4.1.2	Monitoring Power Supply .....	21
4.2	Power on/off .....	21
4.2.1	Power on SIM800A.....	21
4.2.2	Power off SIM800A .....	22
4.2.3	Restart SIM800A by PWRKEY Pin.....	24
4.3	Reset Function .....	24
4.4	Power Saving Mode.....	25
4.4.1	Minimum Functionality Mode .....	25
4.4.2	Sleep Mode 1 (AT+CSCLK=1) .....	26
4.4.3	Wake up SIM800A from Sleep Mode 1 (AT+CSCLK=1) .....	26
4.4.4	Sleep Mode 2 (AT+CSCLK=2) .....	26
4.4.5	Wake up SIM800A from Sleep Mode 2 (AT+CSCLK=2) .....	26
4.5	RTC Backup .....	26
4.6	Serial Port and USB Interface .....	27
4.6.1	Function of Serial Port .....	28
4.6.2	Serial Port Connection .....	29
4.6.3	USB Interface.....	30
4.6.4	Software Upgrading and Debugging.....	31
4.7	RI Behaviors.....	32
4.8	Audio Interfaces .....	33
4.8.1	Speaker Reference Circuit.....	34
4.8.2	Microphone Reference Circuit.....	34
4.8.3	Audio Electronic Characteristics.....	34
4.8.4	TDD .....	35
4.9	SIM Card Interface .....	35
4.9.1	SIM Card Application .....	35
4.9.2	SIM Card Circuit Design Guide.....	36
4.9.3	Design Considerations for SIM Card Holder .....	37
4.10	DISP Interface .....	38
4.11	Keypad Interface .....	39
4.12	GPIO.....	40
4.13	I2C BUS .....	40

4.14	ADC.....	41
4.15	Network Status Indication .....	41
4.16	Power on Status Indication .....	42
4.17	PWM .....	42
4.18	KPLED .....	43
4.19	Bluetooth .....	44
4.20	Antenna Interface .....	44
4.20.1	GSM Antenna Interface .....	44
4.20.2	Bluetooth Antenna Interface .....	45
<b>5</b>	<b>PCB Layout .....</b>	<b>47</b>
5.1	PIN Assignment.....	47
5.2	Principle of PCB Layout.....	48
5.2.1	Antenna .....	48
5.2.2.	Power Supply .....	48
5.2.3	SIM Card Interface.....	48
5.2.4	Audio Interface.....	48
5.2.5	Others .....	48
<b>6</b>	<b>Electrical, Reliability and Radio Characteristics.....</b>	<b>49</b>
6.1	Absolute Maximum Ratings .....	49
6.2	Recommended Operating Conditions.....	49
6.3	Digital Interface Characteristics .....	49
6.4	SIM Card Interface Characteristics .....	49
6.5	SIM_VDD Characteristics.....	50
6.6	VDD_EXT Characteristics .....	50
6.7	VRTC Characteristics .....	50
6.8	Current Consumption (VBAT = 4V) .....	51
6.9	Electro-Static Discharge .....	51
6.10	Radio Characteristics.....	52
6.10.1	Module RF Output Power.....	52
6.10.2	Module RF Receive Sensitivity .....	53
6.10.3	Module Operating Frequencies.....	53
<b>7</b>	<b>Manufacturing .....</b>	<b>54</b>
7.1	Top and Bottom View of SIM800A .....	54
7.2	Typical Solder Reflow Profile .....	54
7.3	The Moisture Sensitivity Level .....	55
7.4	Baking Requirements .....	55
<b>8.</b>	<b>Appendix .....</b>	<b>56</b>
I.	Related Documents.....	56
II.	Terms and Abbreviations .....	57
III.	Safety Caution .....	59

## Table Index

TABLE 1: SIM800A KEY FEATURES .....	10
TABLE 2: CODING SCHEMES AND MAXIMUM NET DATA RATES OVER AIR INTERFACE .....	12
TABLE 3: OVERVIEW OF OPERATING MODES .....	12
TABLE 4: PIN DESCRIPTION .....	15
TABLE 5: RECOMMENDED ZENER DIODE .....	20
TABLE 6: ELECTRONIC CHARACTERISTIC OF THE RESET PIN .....	24
TABLE 7: CURRENT CONSUMPTION OF MINIMUM FUNCTIONALITY MODE .....	25
TABLE 8: SERIAL PORT AND USB PIN DEFINITION .....	27
TABLE 9: SERIAL PORT CHARACTERISTICS .....	28
TABLE 10: VBUS CHARACTERISTICS .....	31
TABLE 11: RI BEHAVIORS .....	32
TABLE 12: AUDIO INTERFACE DEFINITION .....	33
TABLE 13: MICROPHONE INPUT CHARACTERISTICS .....	34
TABLE 14: AUDIO OUTPUT CHARACTERISTICS .....	35
TABLE 15: SIM PIN DEFINITION .....	35
TABLE 16: PIN DESCRIPTION (MOLEX SIM CARD HOLDER) .....	37
TABLE 17: PIN DESCRIPTION (AMPHENOL SIM CARD HOLDER) .....	38
TABLE 18: PIN DEFINITION OF DISP INTERFACE .....	38
TABLE 19: PIN DEFINITION OF THE KEYPAD INTERFACE .....	39
TABLE 20: PIN DEFINITION OF THE GPIO .....	40
TABLE 21: PIN DEFINITION OF THE I2C .....	41
TABLE 22: PIN DEFINITION OF ADC .....	41
TABLE 23: ADC SPECIFICATION .....	41
TABLE 24: PIN DEFINITION OF THE STATUS .....	41
TABLE 25: STATUS OF THE NETLIGHT PIN .....	41
TABLE 26: PIN DEFINITION OF THE STATUS .....	42
TABLE 27: PIN DEFINITION OF THE PWM .....	42
TABLE 28: PWM OUTPUT CHARACTERISTICS .....	43
TABLE 29: PIN DEFINITION OF THE KPLED .....	43
TABLE 30: KPLED SPECIFICATION .....	43
TABLE 31: RECOMMENDED TVS FOR GSM ANTENNA INTERFACE .....	45
TABLE 32: ABSOLUTE MAXIMUM RATINGS .....	49
TABLE 33: RECOMMENDED OPERATING CONDITIONS .....	49
TABLE 34: DIGITAL INTERFACE CHARACTERISTICS .....	49
TABLE 35: SIM CARD INTERFACE CHARACTERISTICS .....	49
TABLE 36: SIM_VDD CHARACTERISTICS .....	50
TABLE 37: VDD_EXT CHARACTERISTICS .....	50
TABLE 38: VRTC CHARACTERISTICS .....	50
TABLE 39: CURRENT CONSUMPTION .....	51
TABLE 40: THE ESD CHARACTERISTICS (TEMPERATURE: 25°C, HUMIDITY: 45 %) .....	52
TABLE 41: EGSM 900 CONDUCTED RF OUTPUT POWER .....	52
TABLE 42: DCS 1800 CONDUCTED RF OUTPUT POWER .....	52
TABLE 43: CONDUCTED RF RECEIVE SENSITIVITY .....	53
TABLE 44: OPERATING FREQUENCIES .....	53
TABLE 45: MOISTURE CLASSIFICATION LEVEL AND FLOOR LIFE .....	55

TABLE 46: BAKING REQUIREMENTS .....	55
TABLE 47: RELATED DOCUMENTS .....	56
TABLE 48: TERMS AND ABBREVIATIONS.....	57
TABLE 49: SAFETY CAUTION.....	59

## Figure Index

FIGURE 1: SIM800A FUNCTIONAL DIAGRAM.....	13
FIGURE 2: SIM800A PIN OUT DIAGRAM (TOP VIEW) .....	14
FIGURE 3: DIMENSIONS OF SIM800A (UNIT: MM) .....	17
FIGURE 4: RECOMMENDED PCB FOOTPRINT OUTLINE (UNIT: MM) .....	18
FIGURE 5: REFERENCE CIRCUIT OF THE LDO POWER SUPPLY .....	19
FIGURE 6: REFERENCE CIRCUIT OF THE DC-DC POWER SUPPLY .....	19
FIGURE 7: REFERENCE CIRCUIT OF THE VBAT INPUT.....	20
FIGURE 8: VBAT VOLTAGE DROP DURING MAX POWER TRANSMITTING.....	20
FIGURE 9: THE LOW LIMIT OF VBAT VOLTAGE DROP DURING TRANSMITTING .....	21
FIGURE 10: POWERED ON/DOWN MODULE USING TRANSISTOR.....	21
FIGURE 11: POWERED ON/DOWN MODULE USING BUTTON .....	21
FIGURE 12: TIMING OF POWER ON MODULE.....	22
FIGURE 13: TIMING OF POWER OFF SIM800A BY PWRKEY .....	22
FIGURE 14: TIMING OF RESTART SIM800A .....	24
FIGURE 15: RESET CIRCUIT.....	24
FIGURE 16: RESET TIMING .....	25
FIGURE 17: RTC SUPPLY FROM CAPACITOR.....	27
FIGURE 18: RTC SUPPLY FROM NON-CHARGEABLE BATTERY .....	27
FIGURE 19: RTC SUPPLY FROM RECHARGEABLE BATTERY .....	27
FIGURE 20: CONNECTION OF THE SERIAL INTERFACES.....	29
FIGURE 21: LEVEL CONVERTING BY RESISTOR.....	29
FIGURE 22: LEVEL CONVERTING BY DIODES.....	30
FIGURE 23: TX LEVEL CONVERTING BY TRANSISTOR.....	30
FIGURE 24: RX LEVEL CONVERTING BY TRANSISTOR .....	30
FIGURE 25: USB REFERENCE CIRCUIT .....	31
FIGURE 26: CONNECTION FOR SOFTWARE UPGRADING AND DEBUGGING THROUGH UART .....	32
FIGURE 27: RI BEHAVIOUR OF VOICE CALLING AS A RECEIVER.....	32
FIGURE 28: RI BEHAVIOUR OF URC OR RECEIVE SMS .....	33
FIGURE 29: RI BEHAVIOUR AS A CALLER .....	33
FIGURE 30: SPEAKER REFERENCE CIRCUIT .....	34
FIGURE 31 : MICROPHONE REFERENCE CIRCUIT.....	34
FIGURE 32: REFERENCE CIRCUIT OF THE 8-PIN SIM CARD HOLDER.....	36
FIGURE 33: REFERENCE CIRCUIT OF THE 6-PIN SIM CARD HOLDER.....	36
FIGURE 34: MOLEX 91228 SIM CARD HOLDER .....	37
FIGURE 35: AMPHENOL C707 10M006 5122 SIM CARD HOLDER.....	38
FIGURE 36: CONNECTION OF DISP INTERFACE.....	39
FIGURE 37: REFERENCE CIRCUIT OF THE KEYPAD INTERFACE .....	40
FIGURE 38: REFERENCE CIRCUIT OF NETLIGHT .....	42
FIGURE 39: REFERENCE CIRCUIT OF PWM DRIVE BUZZER.....	43
FIGURE 40: KPLED DRIVER REFERENCE CIRCUIT.....	43
FIGURE 41: GSM ANTENNA MATCHING CIRCUIT .....	44
FIGURE 42: GSM SIMPLE ANTENNA MATCHING CIRCUIT .....	45
FIGURE 43: BLUETOOTH ANTENNA MATCHING CIRCUIT .....	45
FIGURE 44: PIN ASSIGNMENT.....	47
FIGURE 45: TOP AND BOTTOM VIEW OF SIM800A .....	54

---

FIGURE 46: TYPICAL SOLDER REFLOW PROFILE ..... 54



## Version History

Date	Version	Description of change	Author
2015-08-27	1.00	Initial release	Yan Zhang Hailin Yang
2016-01-11	1.01	Update Table 4: Add pin description about KPLED Modify pin descriptions about I2C SCL/SDA Update 5.2.2 Modify the description about layout principle Update Figure 45	Yan Zhang
2016-06-30	1.02	Update Figure 41 and 42: add a TVS; Update Table 31, add recommendation ESD component; Update 4.2.2: Add the note about over/under voltage power off; Delete the descriptions about over/under temperature power off Update Table 34: Digital interface characteristics; Delete the descriptions about multiplex function; Update Figure 3: add the mark of first pad	LiuQiang Yan Zhang

## 1 Introduction

This document describes SIM800A hardware interface in great detail.

This document can help users understand both the interface specifications and the electrical and mechanical details of SIM800A quickly. With the help of this document and other SIM800A application notes or user guide, users can use SIM800A to design various applications quickly.

## 2 SIM800A Overview

Designed for global market, SIM800A is a Dual-band GSM/GPRS module that works on frequencies EGSM 900MHz and DCS 1800MHz . SIM800A features GPRS multi-slot class 12/ class 10 (optional) and supports the GPRS coding schemes CS-1, CS-2, CS-3 and CS-4.

With a tiny configuration of 24\*24\*3mm, SIM800A can meet almost all the space requirements in users' applications, such as smart phone, PDA and other mobile devices.

SIM800A is a SMT package with 68 pads, and provides hardware interfaces as below:

- One full function UART port
- One USB port for debugging and firmware upgrading
- Audio channel which includes a microphone input and a receiver output
- One SIM card interface
- Support up to 4\*5 Keypads
- One display interface
- One I2C master interface for peripheral management
- Programmable general purpose input and output
- Two PWM output
- One ADC input
- Bluetooth antenna interface
- GSM antenna interface

SIM800A is designed with power saving technique so that the current consumption is as low as 0.55mA in sleep mode.

SIM800A integrates TCP/IP protocol and extended TCP/IP AT commands which are very useful for data transfer applications. For details about TCP/IP applications, please refer to *document* <sup>[2]</sup>.

### 2.1 SIM800A Key Features

**Table 1: SIM800A key features**

Feature	Implementation
Power supply	3.4V ~ 4.4V
Power saving	Typical power consumption in sleep mode is 0.55mA ( AT+CFUN=0 )

Frequency bands	<ul style="list-style-type: none"> <li>● SIM800A Dual-band: EGSM 900, DCS 1800</li> <li>● SIM800A can search the 4 frequency bands automatically. The frequency bands also can be set by AT command “AT+CBAND”. For details, please refer to <i>document</i> <sup>[1]</sup></li> <li>● Compliant to GSM Phase 2/2+</li> </ul>
Transmitting power	<ul style="list-style-type: none"> <li>● Class 4 (2W) at EGSM 900</li> <li>● Class 1 (1W) at DCS 1800</li> </ul>
GPRS connectivity	<ul style="list-style-type: none"> <li>● GPRS multi-slot class 12 (default)</li> <li>● GPRS multi-slot class 1~12 (option)</li> </ul>
Temperature range	<ul style="list-style-type: none"> <li>● Operation temperature: -40 °C ~ +85 °C</li> <li>● Storage temperature -45 °C ~ +90 °C</li> </ul>
Data GPRS	<ul style="list-style-type: none"> <li>● GPRS data downlink transfer: max. 85.6 kbps</li> <li>● GPRS data uplink transfer: max. 85.6 kbps</li> <li>● Coding scheme: CS-1, CS-2, CS-3 and CS-4</li> <li>● Integrate the TCP/IP protocol.</li> <li>● Support Packet Broadcast Control Channel (PBCCH)</li> </ul>
USSD	<ul style="list-style-type: none"> <li>● Unstructured Supplementary Services Data (USSD) support</li> </ul>
SMS	<ul style="list-style-type: none"> <li>● MT, MO, CB, Text and PDU mode</li> <li>● SMS storage: SIM card</li> </ul>
FAX	Group 3 Class 1
SIM interface	Support SIM card: 1.8V, 3V
External antenna	Antenna pad
Audio features	Speech codec modes: <ul style="list-style-type: none"> <li>● Half Rate (ETS 06.20)</li> <li>● Full Rate (ETS 06.10)</li> <li>● Enhanced Full Rate (ETS 06.50 / 06.60 / 06.80)</li> <li>● Adaptive multi rate (AMR)</li> <li>● Echo Cancellation</li> <li>● Noise Suppression</li> </ul>
Serial port and USB	<b>Serial port:</b> <ul style="list-style-type: none"> <li>● Full modem serial port</li> <li>● Can be used for AT commands or data stream</li> <li>● Support RTS/CTS hardware handshake</li> <li>● Comply with GSM 07.10 Multiplexer Protocol</li> <li>● Support auto baud detect from 1200 bps to 115200bps</li> </ul> <b>USB:</b> <ul style="list-style-type: none"> <li>● For debugging and upgrading firmware</li> </ul>
Phonebook management	Support phonebook types: SM, FD, LD, RC, ON, MC.
SIM application toolkit	GSM 11.14 Release 99
Real time clock	Support RTC
Physical characteristics	Size: 24*24*3mm Weight: 3.1g
Firmware upgrading	Upgrade firmware via USB port

**Table 2: Coding schemes and maximum net data rates over air interface**

Coding scheme	1 timeslot	2 timeslot	4 timeslot
CS-1	9.05kbps	18.1kbps	36.2kbps
CS-2	13.4kbps	26.8kbps	53.6kbps
CS-3	15.6kbps	31.2kbps	62.4kbps
CS-4	21.4kbps	42.8kbps	85.6kbps

## 2.2 Operating Modes

The table below summarizes the various operating modes of SIM800A.

**Table 3: Overview of operating modes**

Mode	Function
Normal operation	GSM/GPRS SLEEP Module will automatically go into sleep mode when the sleep mode is enabled and there is no on air or hardware interrupt (such as GPIO interrupt or data on serial port). In this case, the current consumption of module will reduce to the minimal level, and the module can still receive paging message and SMS.
	GSM IDLE Software is active. Module has been registered to the GSM network and is ready to communicate.
	GSM TALK Connection between two subscribers is in progress. In this case, the power consumption depends on network settings such as DTX off/on, FR/EFR/HR, hopping sequences, antenna.
	GPRS STANDBY Module is ready for GPRS data transfer, but no data is currently sent or received. In this case, power consumption depends on network settings and GPRS configuration.
	GPRS DATA There is GPRS data transfer (PPP or TCP or UDP) in progress. In this case, power consumption is related with network settings (e.g. power control level), uplink/downlink data rates and GPRS configuration (e.g. used multi-slot settings).
Power off	Normal power off by sending the AT command “AT+CPOWD=1” or using the PWRKEY. The power management unit shuts down the power supply for the baseband part of the module, and only the power supply for the RTC is remained. Software is not active. The serial port is not accessible. Power supply (connected to VBAT) remains applied.
Minimum functionality mode	AT command “AT+CFUN” can be used to set the module to a minimum functionality mode. In this mode, the RF function and SIM card function can be disabled, but the serial port is still accessible. The power consumption in this mode is lower than normal mode.

### 2.3 SIM800A Functional Diagram

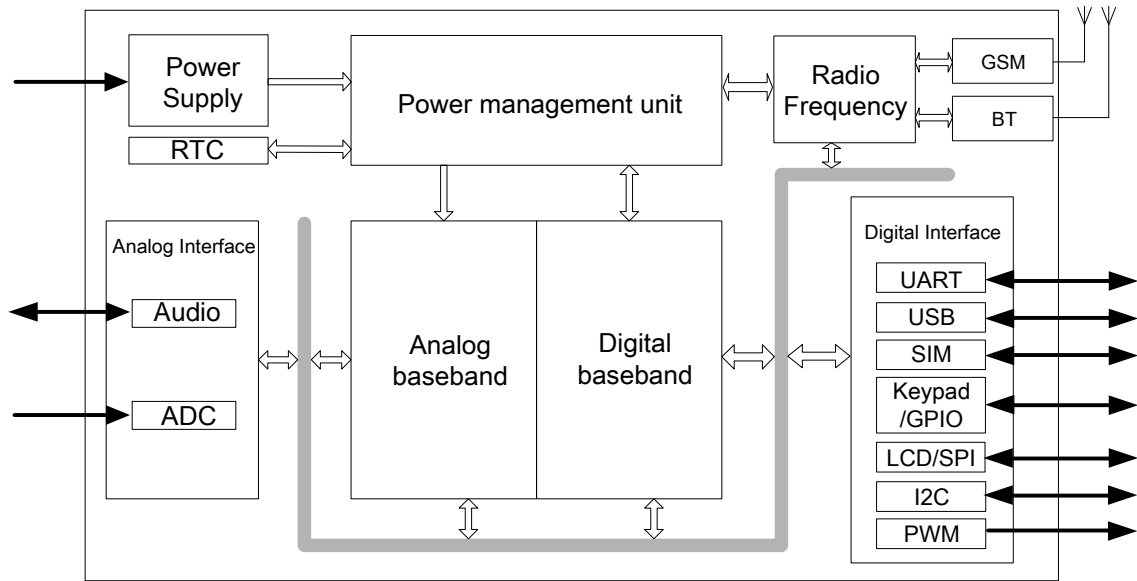


Figure 1: SIM800A functional diagram

### 3 Package Information

#### 3.1 Pin out Diagram

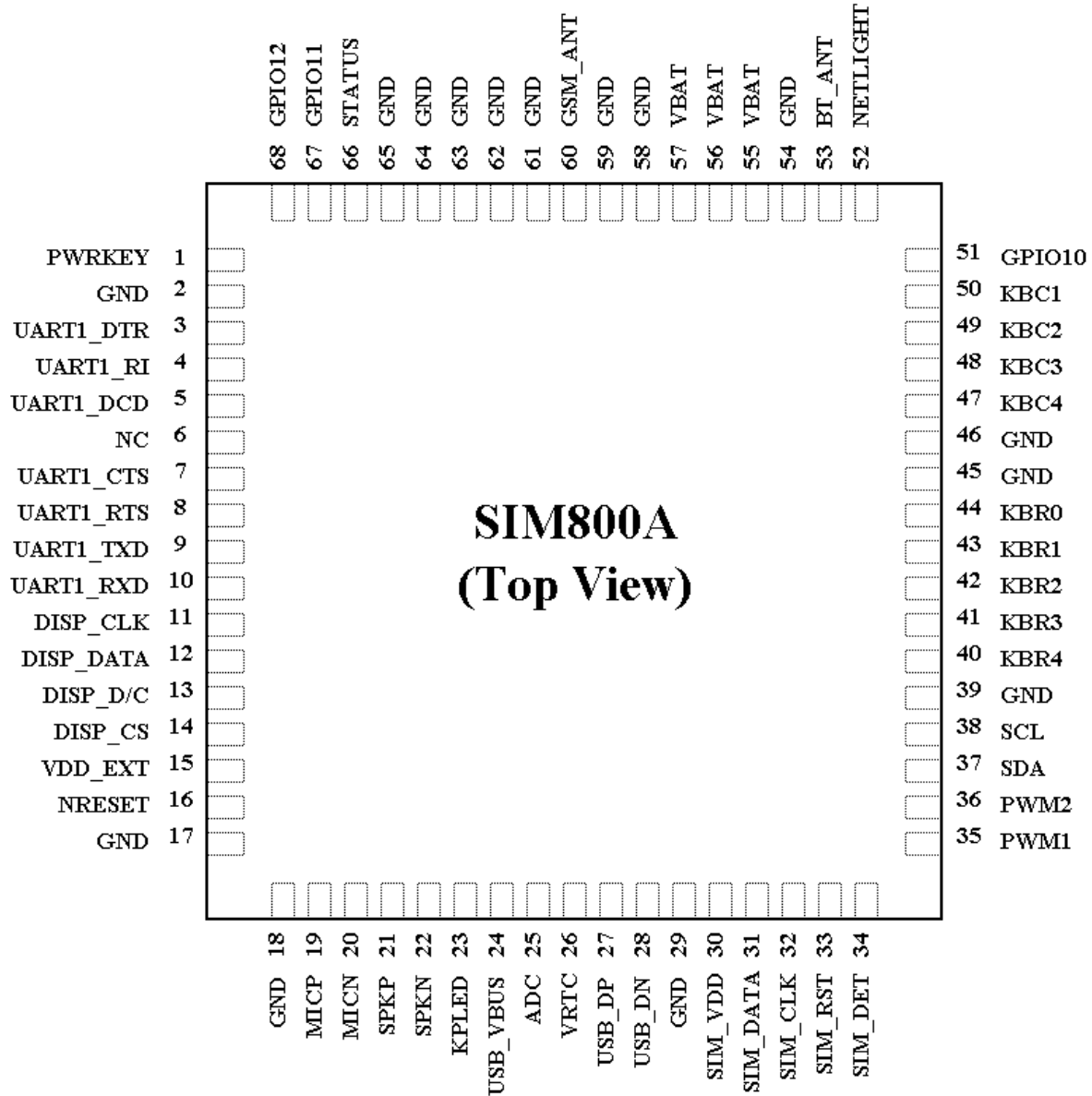


Figure 2: SIM800A pin out diagram (Top view)

## 3.2 Pin Description

**Table 4: Pin description**

Pin name	Pin number	I/O	Description	Comment
<b>Power supply</b>				
VBAT	55,56,57	I	Power supply	
VRTC	26	I/O	Power supply for RTC	It is recommended to connect with a battery or a capacitor (e.g. 4.7uF)
VDD_EXT	15	O	2.8V output power supply	Left floating if unused
GND	2,17,18,29, 39,45,46,54, 58,59,61,62, 63,64,65	-	Ground	
<b>Power on/off</b>				
PWRKEY	1	I	PWRKEY should be pulled low more than 1 second then released to power on/off the module.	Pulled up internally already
<b>Audio interfaces</b>				
MICP	19	I	Differential audio input	Left floating if unused
MICN	20			
SPKP	21	O	Differential audio output	
SPKN	22			
<b>Status</b>				
STATUS	66	O	Power on status indication	Left floating if unused
NETLIGHT	52	O	Network status indication	
<b>LCD interface</b>				
DISP_CLK	11	O	Display interface	Left floating if unused
DISP_DATA	12	I/O		
DISP_D/C	13	O		
DISP_CS	14	O		
<b>I2C interface</b>				
SDA	37	I/O	I2C bus data	Left floating if unused
SCL	38	O	I2C bus clock	
<b>Keypad interface / GPIO</b>				
KBR0	44	I/O	keypad row 0	Left floating if unused; KBC1 can not be pulled down during power on procedure
KBR1	43		keypad row 1	
KBR2	42		keypad row 2	
KBR3	41		keypad row 3	
KBR4	40		keypad row 4	
KBC1	50		keypad column 1	

KBC2	49		keypad column 2	
KBC3	48		keypad column 3	
KBC4	47		keypad column 4	
GPIO10	51		GPIO10	Left floating if unused
GPIO11	67		GPIO11	Do not pull up externally; Left floating if unused
GPIO12	68		GPIO12	Left floating if unused
<b>Serial port</b>				
UART1_RXD	10	I	Receive data	
UART1_TXD	9	O	Transmit data	
UART1_RTS	8	I	Request to send	
UART1_CTS	7	O	Clear to send	Left floating if unused
UART1_DCD	5	O	Data carrier detect	
UART1_RI	4	O	Ring indicator	
UART1_DTR	3	I	Data terminal ready	
<b>USB interface</b>				
USB_VBUS	24	I		
USB_DP	27	I/O	For debugging & upgrading firmware	Left floating if unused
USB_DN	28	I/O		
<b>SIM interface</b>				
SIM_VDD	30	O	Voltage supply for SIM card. Support 1.8V or 3V SIM card	
SIM_DATA	31	I/O	SIM data input/output	Should be protected against ESD with TVS diode
SIM_CLK	32	O	SIM card clock	
SIM_RST	33	O	SIM card reset	
SIM_DET	34	I	SIM card detection	Left floating if unused
<b>ADC</b>				
ADC	25	I	Input voltage range: 0V ~ 2.8V	Left floating if unused
<b>External reset</b>				
NRESET	16	I	Reset input, active low	Left floating if unused
<b>Pulse width modulation( PWM )</b>				
PWM1	35	O	Pulse-Width Modulation	Left floating if unused
PWM2	36	O	Pulse-Width Modulation	
<b>RF interface</b>				
GSM_ANT	60	I/O	GSM antenna	Impedence must be controlled to 50Ω
BT_ANT	53	I/O	Bluetooth antenna	Impedence must be controlled to 50Ω
<b>Not connect</b>				
KPLED	23	I	Sink current for keypad LED	Left floating if unused
NC	6	-	No connection	Do not connect



### 3.3 Package Dimensions

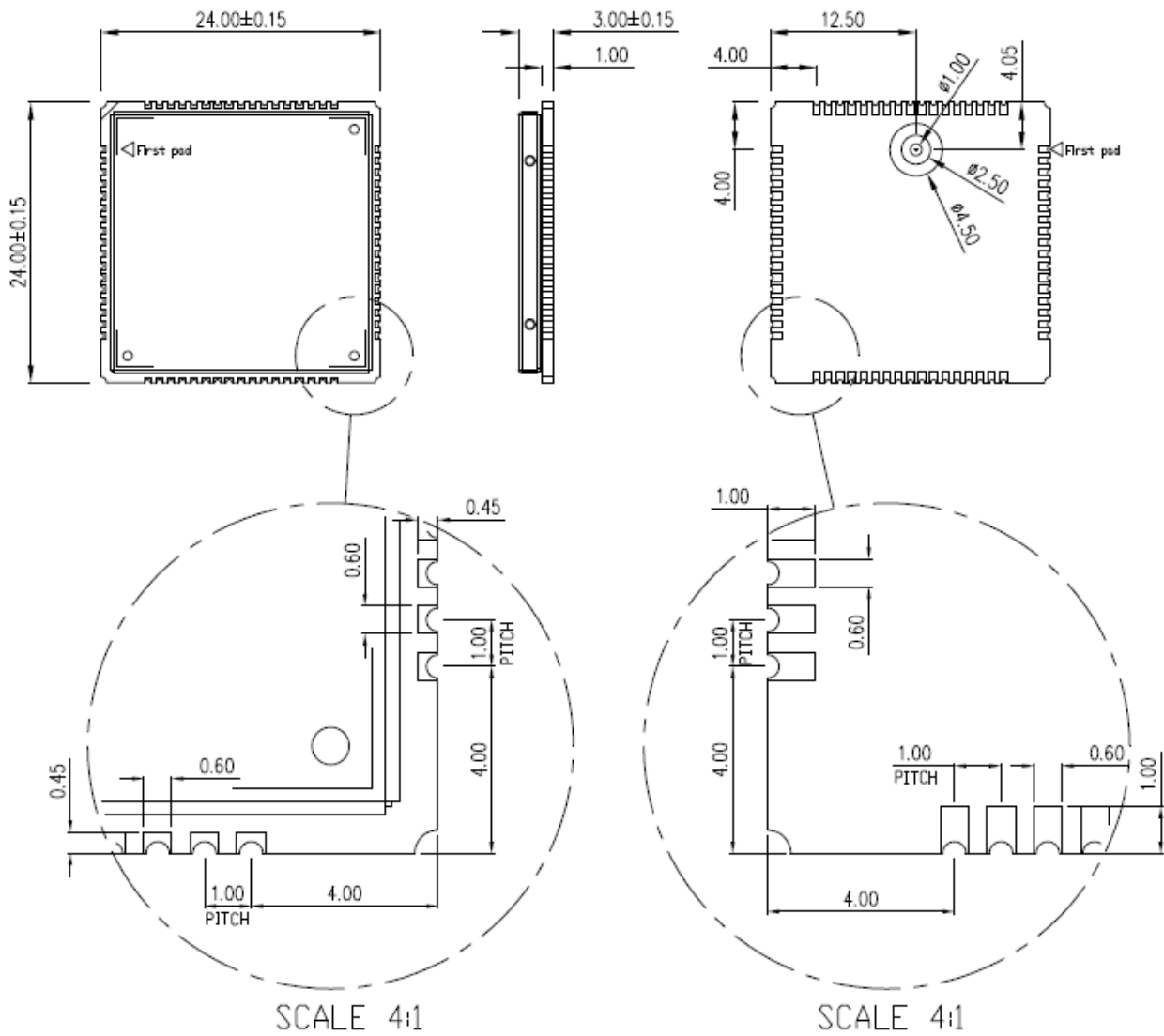
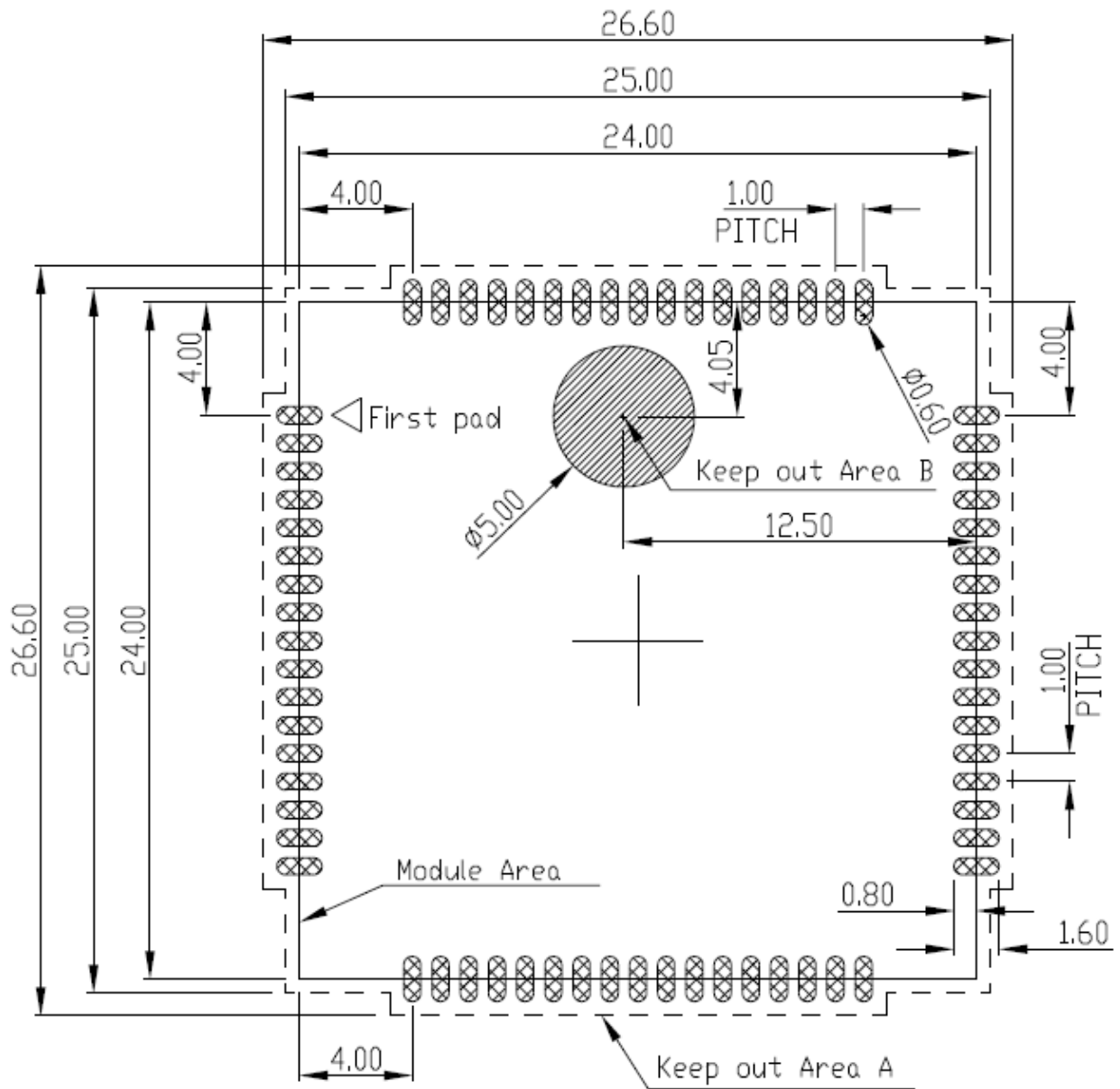


Figure 3: Dimensions of SIM800A (Unit: mm)



**Figure 4: Recommended PCB footprint outline (Unit: mm)**

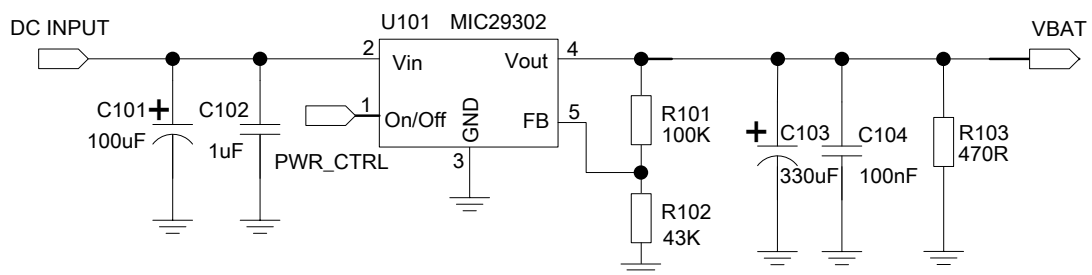
*Note: Keep copper out of area A. Do not place via in area B to avoid short circuit between the vias on customer board and the test points on the bottom side of the module.*

## 4 Application Interface

### 4.1 Power Supply

The power supply of SIM800A ranges from 3.4V to 4.4V, and 4.0V is recommended. It must be able to provide sufficient current up to 2A for the high-power transmitting.

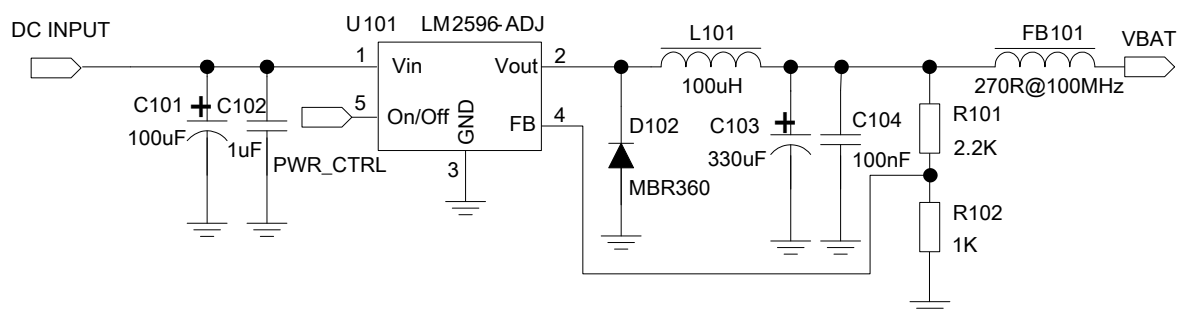
If the DC input voltage is +5V and customers do not care about the power efficiency, a high-current low-dropout regulator is recommended. The following figure is the reference design.



**Figure 5: Reference circuit of the LDO power supply**

*Note: To ensure a proper behavior of the regulator under light load, an extra minimum load (R103 in Figure 5) is required, because the current SIM800A consumed is very small in sleep mode and power off mode. For more details about minimum load, please refer to specification of MIC29302.*

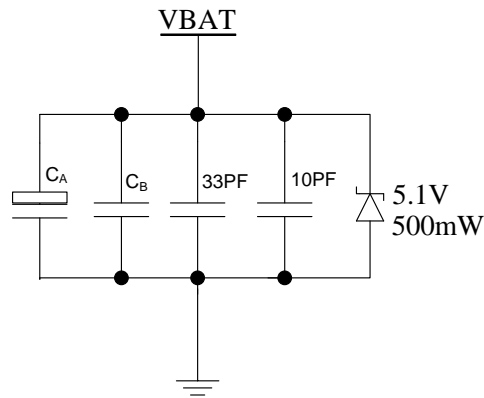
To increase power efficiency, the switching mode DC-DC converter is preferable, especially when DC input voltage is quite high. The following figure is the reference design, and it is recommended to reserve a proper ferrite bead (FB101 in Figure 6) in series for EMI suppression.



**Figure 6: Reference circuit of the DC-DC power supply**

For battery-powered application, the 3.7V lithium battery can be connected to SIM800A VBAT pins directly, but other types of battery must be used carefully, since their maximum voltage may rise over the absolute maximum voltage of the module. When battery is used, the total impedance between battery and VBAT pins should be less than 150mΩ.

In any case mentioned above, at the VBAT input pin side, please take below circuit as a reference:



**Figure 7: Reference circuit of the VBAT input**

Where  $C_A$  is a 100 $\mu$ F tantalum capacitor with low ESR;  $C_B$  could be a 1~10 $\mu$ F ceramic capacitor; 33PF and 10PF capacitors are used for eliminating the high frequency interference; 5.1V/500mW zener diode can protect the module against voltage surge.

All of these components should be placed as close to VBAT pins as possible.

**Table 5: Recommended zener diode**

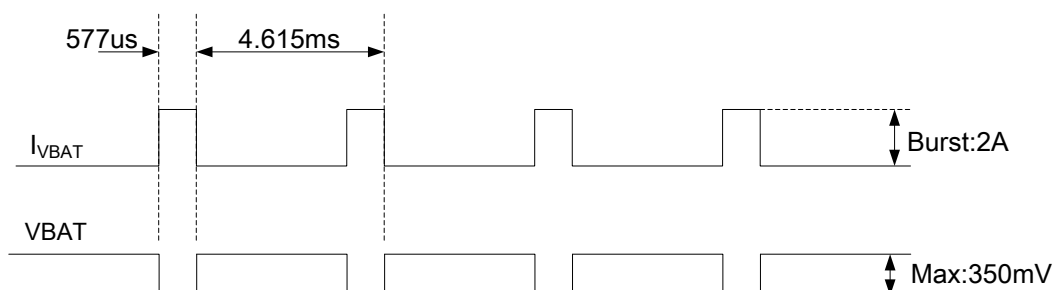
	Vendor	Part number	Power(watts)	Packages
1	On semi	MMSZ5231BT1G	500mW	SOD123
2	Prisemi	PZ3D4V2H	500mW	SOD323
3	Vishay	MMSZ4689-V	500mW	SOD123
4	Crownpo	CDZ55C5V1SM	500mW	0805

In addition, VBAT voltage will drop during the transmitting. The following figure shows the VBAT voltage drop during maximum power transmitting under the condition:

VBAT=4.0V

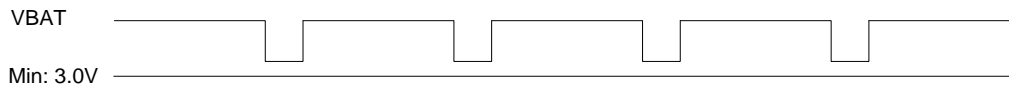
$C_A=100\mu$ F tantalum capacitor (ESR=0.7 $\Omega$ )

$C_B=1\mu$ F ceramic capacitor



**Figure 8: VBAT voltage drop during max power transmitting**

However, hardware may shutdown once the voltage drops below 3.0V, which must be avoid.



**Figure 9: The low limit of VBAT voltage drop during transmitting**

To decrease voltage drop, the PCB traces from power supply to VBAT pins must be wide and short enough. The power IC and the bypass capacitor should be placed as close to the module as possible.

#### 4.1.1 Power Supply Pins

Pin 55, 56, 57 are VBAT input pins, and pin 62, 63, 64, 65 are the main GND for VBAT. The other GND pins should be connected as well.

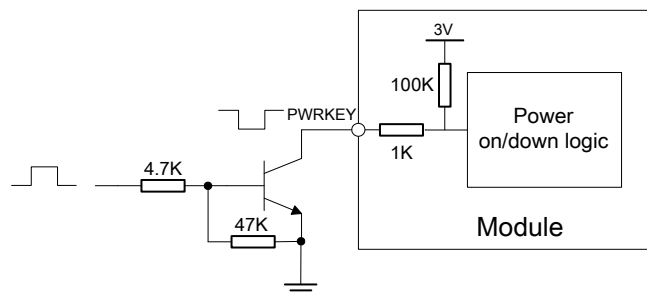
#### 4.1.2 Monitoring Power Supply

The AT command “AT+CBC” can be used to monitor the VBAT voltage. For detail, please refer to *document*<sup>[1]</sup>.

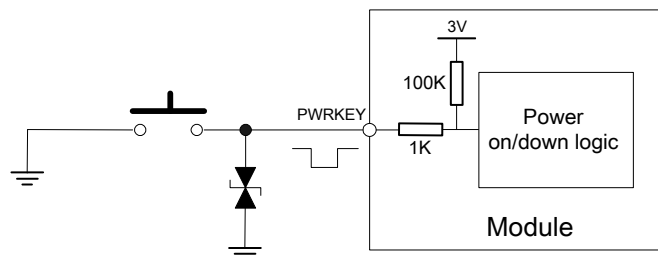
### 4.2 Power on/off

#### 4.2.1 Power on SIM800A

Users can power on SIM800A by pulling down the PWRKEY pin for more than 1 second then release. This pin is already pulled up to 3V internally, so external pull up is not necessary. Reference circuit is shown as below:

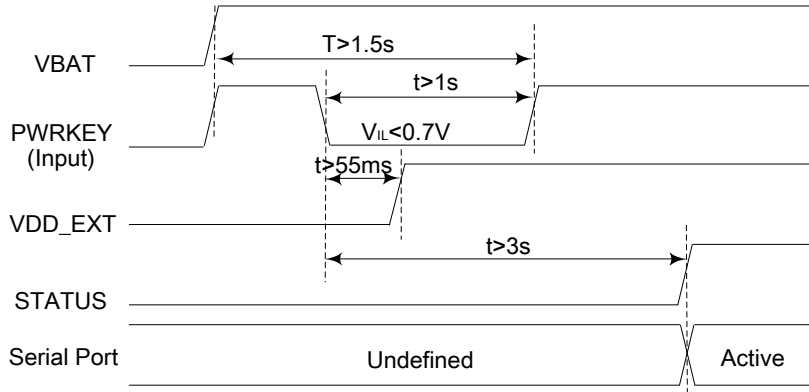


**Figure 10: Powered on/down module using transistor**



**Figure 11: Powered on/down module using button**

The power on sequence is illustrated as following figure:



**Figure 12: Timing of power on module**

If a fixed baud rate was set, when power on procedure is completed, SIM800A will send following URC to indicate that the module is ready to operate:

***RDY***

This URC does not appear when auto baud detect function is active.

*Note: Users can use AT command “AT+IPR=x” to set a fixed baud rate and save the configuration to non-volatile flash memory. After the configuration is saved as fixed baud rate, the Code “RDY” could be received from the serial port every time when SIM800A is powered on. For details, please refer to the chapter “AT+IPR” in document <sup>[1]</sup>.*

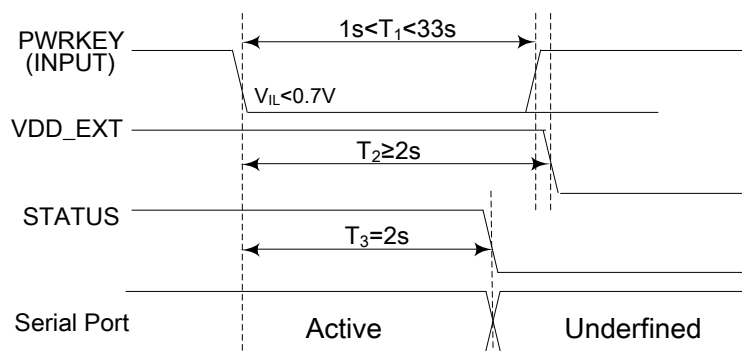
#### 4.2.2 Power off SIM800A

SIM800A will be powered off in the following situations:

- Normal power off procedure: power off SIM800A by the PWRKEY pin
- Normal power off procedure: power off SIM800A by AT command “AT+CPOWD=1”
- Abnormal power off: over-voltage or under-voltage automatic power off

##### 4.2.2.1 Power off SIM800A by the PWRKEY Pin

Users can power off SIM800A by pulling down the PWRKEY pin for more than 1 second then release. The power off sequence is illustrated as below:



**Figure 13: Timing of power off SIM800A by PWRKEY**

*Note:*

1. *If the PWRKEY pull down time exceeds 33s, SIM800A module will power up again.*
2. *VDD\_EXT will be turned off after PWRKEY was released for at least 55ms and STATUS was changed to low.*  
*If  $1s < T1 < 2s$ , then  $T2 \geq 2s$*   
*If  $2s \leq T1 < 33s$ , then  $T2 > T1 + 55ms$*

This procedure makes the module log off from the network and allows the software to enter into a secure state to save data before completely shut down.

Before the completion of the power off procedure, the module will send URC:

***NORMAL POWER OFF***

At this moment, AT commands can not be executed any more, and only the RTC is still active. Power off mode can also be indicated by STATUS pin, which is at low level at this time.

#### **4.2.2.2 Power off SIM800A by AT Command**

SIM800A can be powered down by AT command “AT+CPOWD=1”. This procedure makes the module log off from the network and allows the software to enter into a secure state to save data before completely shut down.

Before completing the power off procedure, the module will send URC:

***NORMAL POWER OFF***

At this moment, AT commands can not be executed any more, and only the RTC is still active. Power off mode can also be indicated by STATUS pin, which is at low level at this time.

For details about the AT command “AT+CPOWD”, please refer to *document* <sup>[1]</sup>.

#### **4.2.2.3 Over-voltage or Under-voltage Power off**

The module software monitors the VBAT voltage constantly.

If the voltage  $\leq 3.5V$ , the following URC will be reported:

***UNDER-VOLTAGE WARNING***

If the voltage  $\geq 4.3V$ , the following URC will be reported:

***OVER-VOLTAGE WARNING***

If the voltage  $< 3.4V$ , the following URC will be reported, and the module will be automatically powered off.

***UNDER-VOLTAGE POWER OFF***

If the voltage  $> 4.4V$ , the following URC will be reported, and the module will be automatically powered off.

***OVER-VOLTAGE POWER OFF***

At this moment, AT commands can not be executed any more, and only the RTC is still active. Power off mode can also be indicated by STATUS pin, which is at low level at this time.

*Note :*

1. *This function is disabled by default. AT command “AT+CBATCHK=1” could be used to enable this function. For details about this command please refer to document [1].*
2. *Digital interface should comply with table 34 strictly when using this function.*

### 4.2.3 Restart SIM800A by PWRKEY Pin

When users need to power off the module then restart it, please follow the procedure below:

- 1) Power off the module
- 2) Wait for at least 800ms after STATUS pin changed to low level
- 3) Power on the module

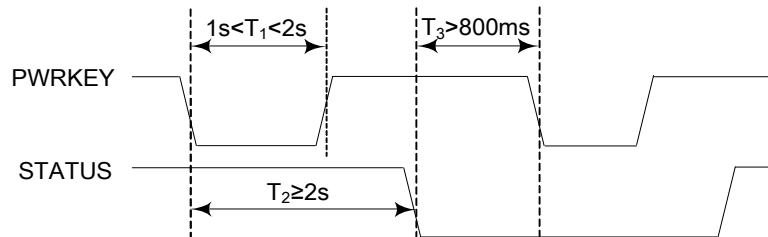


Figure 14: Timing of restart SIM800A

### 4.3 Reset Function

SIM800A provides a reset pin (pin 16) to reset the module. This function is used as an emergency reset only when AT command “AT+CPOWD=1” and the PWRKEY pin do not work. Pull the RESET pin to ground, then the module will reset.

This pin is already isolated from the chipset inside the module, so the external isolation is not necessary.

Following figure shows the internal circuit:

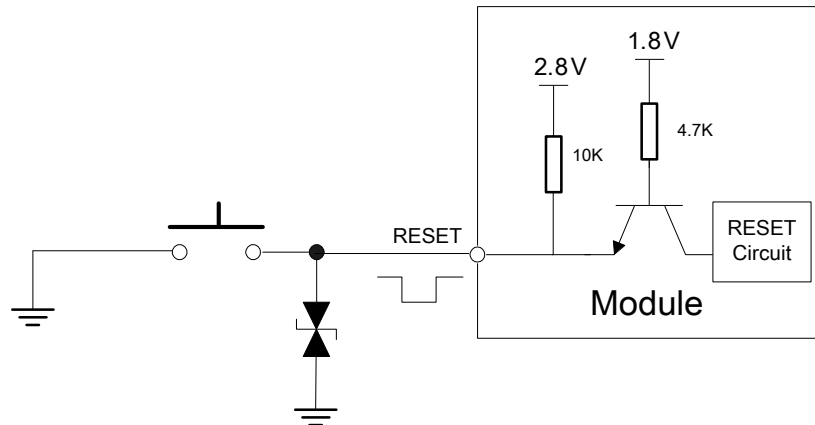


Figure 15: Reset Circuit

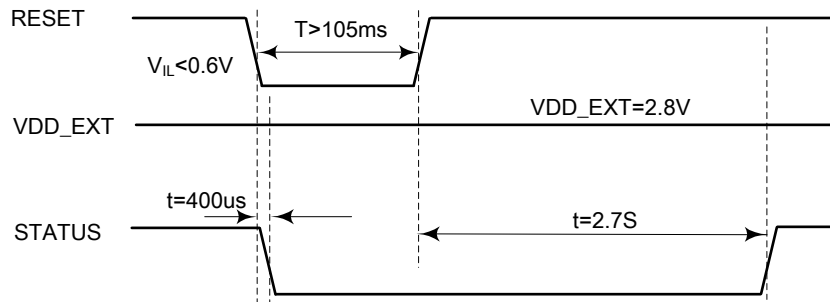
RESET pin is pulled up to 2.8V internally, so the users could set the GPIO as an open-drain output pin when use MCU's GPIO to control it.

Table 6: Electronic characteristic of the RESET Pin

Pin name	Symbol	Min	Typ	Max	Unit
RESET	$V_{IH}$	2.7	-	2.9	V
	$V_{IL}$	-	-	0.6	V
	$T_{pull\ down}$	105		-	mS

The reset sequence is illustrated as below:





**Figure 16: Reset timing**

## 4.4 Power Saving Mode

SIM800A has two power saving modes: minimum functionality mode and sleep mode. The power consumption can be reduced to the minimum when SIM800A is in both sleep mode and minimum functionality mode.

The AT command “AT+CFUN=<fun>” can be used to set the module into minimum functionality mode. And the command “AT+CSCLK=1” or “AT+CSCLK=2” can be used to set the module into sleep mode 1 or 2. In sleep mode 1, whether the module can sleep is controlled by DTR signal, while in sleep mode 2, it is determined by serial port’s RXD status.

*Note: The default setting is “AT+CSCLK=0”, which do not allow the module enter sleep mode. For more details please refer to document <sup>[1]</sup>.*

### 4.4.1 Minimum Functionality Mode

There are three functionality modes, which could be set by the AT command “AT+CFUN=<fun>”. The command provides the choice of the functionality levels <fun>=0, 1, 4.

- 0: minimum functionality mode (disable RF function and SIM card function)
- 1: full functionality mode (default, no function is disabled)
- 4: flight mode (disable RF function)

If SIM800A is set to minimum functionality mode by “AT+CFUN=0”, the RF function and SIM card function will be disabled, and all AT commands correlative with RF and SIM card functions will be invalid. But the serial port is still accessible, no matter which functionality mode it is in.

For detailed information about the AT Command “AT+CFUN=<fun>”, please refer to document <sup>[1]</sup>.

**Table 7: Current consumption of Minimum Functionality Mode**

<fun>	BS-PA-MFRMS	Current consumption in sleep mode (mA)
0	N/A	0.55
1	9	0.85
	5	0.95
	2	1.30

#### 4.4.2 Sleep Mode 1 (AT+CSCLK=1)

Users can control SIM800A module to enter or exit the sleep mode 1 (AT+CSCLK=1) by DTR signal. When DTR is in high level and without interrupt (on air and hardware such as GPIO interrupt or data in serial port), SIM800A will enter sleep mode 1 automatically. In this mode, SIM800A can still receive paging or SMS from network, but the serial port is not accessible.

#### 4.4.3 Wake up SIM800A from Sleep Mode 1 (AT+CSCLK=1)

When SIM800A is in sleep mode 1 (AT+CSCLK=1), the following events can wake up the module:

- DTR is pulled down
- Receive a voice or data call from network
- Receive a SMS from network

*Note: After module has received incoming call or new SMS, serial port can report URC, but the serial port can not input AT command. Only after the DTR pin is pulled to low level for 50ms, the serial port can input AT command.*

#### 4.4.4 Sleep Mode 2 (AT+CSCLK=2)

In this mode, SIM800A will continuously monitor the serial port data signal. When there is no data transfer over 5 seconds on the RXD signal and there is no hardware interrupts (such as GPIO interrupt), SIM800A will enter sleep mode 2 automatically. In this mode, SIM800A can still receive paging or SMS from network.

*Note: The default setting of serial port is auto baud detection, in this case, the module cannot enter sleep mode 2 before the synchronization of serial port baud rate between DTE and DCE.*

#### 4.4.5 Wake up SIM800A from Sleep Mode 2 (AT+CSCLK=2)

When SIM800A is in sleep mode 2 (AT+CSCLK=2), the following events can wake up the module:

- Receive data via main serial port (the first several character will lose)
- Receive a voice or data call from network
- Receive a SMS from network

### 4.5 RTC Backup

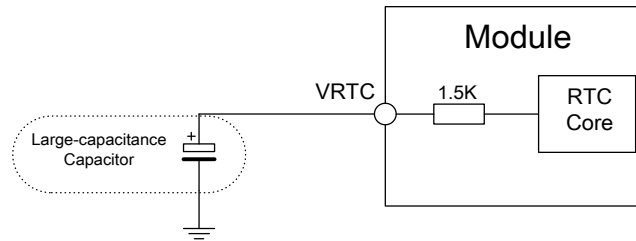
VRTC is the power supply for RTC circuit, and its typical value is 2.8V. To allow the RTC to operate even when VBAT is turned off, it is recommended to connect the VRTC pin to a backup battery or an external large-capacitance capacitor (100uF is recommended).

When VBAT is turned on, RTC circuit is supplied from an internal LDO, and the backup battery or the external capacitor will be charged through VRTC pin.

When VBAT is turned off, RTC circuit will be supplied from the backup battery or the external capacitor.

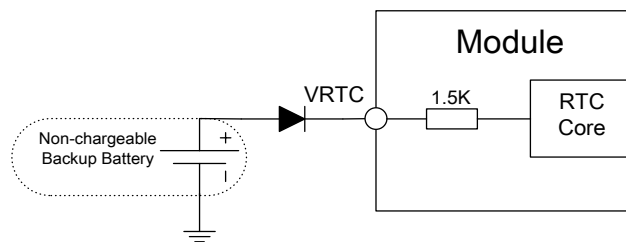
The following figures show various references for RTC backup circuit:

- **External capacitor backup**



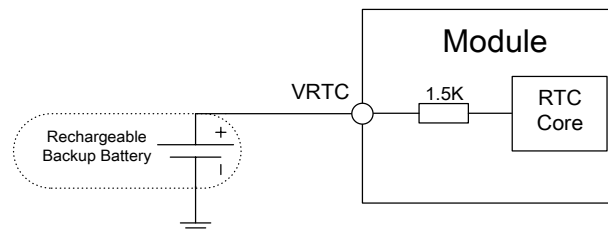
**Figure 17: RTC supply from capacitor**

- **Non-chargeable battery backup**



**Figure 18: RTC supply from non-chargeable battery**

- **Rechargeable battery backup**



**Figure 19: RTC supply from rechargeable battery**

*Note:*

1. For electrical characteristics, please refer to Table 44: VRTC characteristics.
2. The clock error becomes larger when VBAT is turned off and RTC circuit was supplied from the backup battery or the external capacitor.

## 4.6 Serial Port and USB Interface

**Table 8: Serial port and USB pin definition**

	Name	Pin number	Function
Serial port UART1	UART1_DTR	3	Data terminal ready
	UART1_RI	4	Ring indicator
	UART1_DCD	5	Data carrier detect
	UART1_CTS	7	Clear to send

	UART1_RTS	8	Request to send
	UART1_TXD	9	Transmit data
	UART1_RXD	10	Receive data
Serial port UART2 (enabled by command)	GPIO12	68	Compatible with UART2_TXD, Transmit data
	GPIO10	51	Compatible with UART2_RXD, Receive data
USB interface	USB_VBUS	24	USB power supply
	USB_DP	27	USB data line plus
	USB_DN	28	USB data line minus

**Note:**

1. *Hardware flow control is disabled by default. The AT command “AT+IFC=2,2” can enable hardware flow control. The AT command “AT+IFC=0,0” can disable hardware flow control. For more details, please refer to document <sup>[1]</sup>.*
2. *Pin 68 & 51 are configured as GPIO by default. AT command “AT+CMNRP=1” can set them to be serial port UART2.*

**Table 9: Serial port characteristics**

Symbol	Min	Max	Unit
V <sub>IL</sub>	-0.3	0.7	V
V <sub>IH</sub>	2.1	3.1	V
V <sub>OL</sub>	-	0.4	V
V <sub>OH</sub>	2.4	-	V

#### 4.6.1 Function of Serial Port

Serial port UART1:

- Support modem device
- Contain data lines UART1\_TXD, UART1\_RXD, hardware flow control lines UART1\_RTS, UART1\_CTS and status lines UART1\_DTR, UART1\_DCD, UART1\_RI
- Serial port can be used for GPRS service and AT communication
- Serial port supports the following baud rates  
1200, 2400, 4800, 9600, 19200, 38400, 57600 and 115200bps
- The default setting is auto baud detection

Serial port UART2:

- Support AT command
- Serial port supports the following baud rates:  
1200, 2400, 4800, 9600, 19200, 38400, 57600 and 115200bps
- The default setting is auto baud detection

Auto baud detection allows SIM800A to detect the baud rate of the host device automatically. Pay more attention to the following requirements:

- **Synchronization between DTE and DCE:**

When DCE powers on with auto baud detection enabled, firstly, users must send character “A” or “a” to synchronize the baud rate. It is recommended to send “AT” until DTE receives the “OK” response, which means DTE and DCE are correctly synchronized. For more information please refer to the AT command

“AT+IPR”.

● **Restrictions of auto baud detection:**

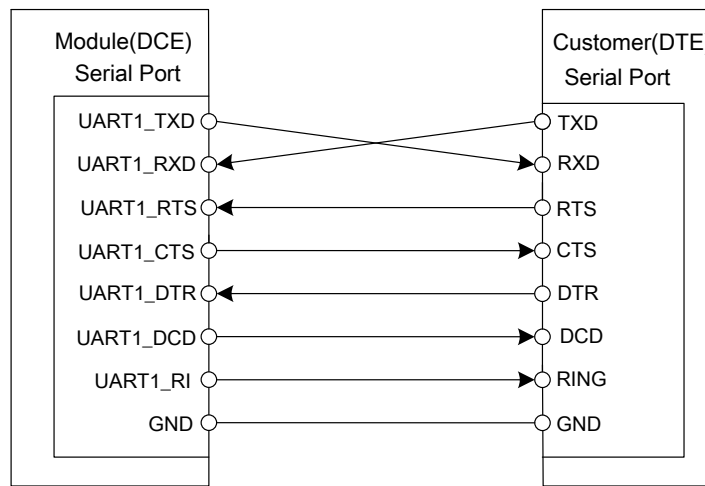
The DTE serial port must be set at 8 data bits, no parity bit and 1 stop bit.

The URC such as "RDY", "+CFUN: 1" and "+CPIN: READY" will not be reported.

*Note: User can use AT command “AT+IPR=x” to set a fixed baud rate and the setting will be saved to non-volatile flash memory automatically. After the configuration is set as fixed baud rate, the URC such as "RDY", "+CFUN: 1" and "+CPIN: READY" will be reported when SIM800A is powered on.*

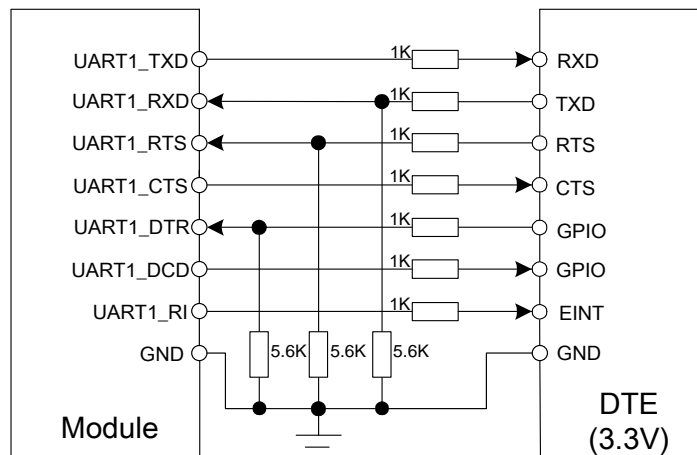
**4.6.2 Serial Port Connection**

The following figure shows the connection between module side (DCE) and customer side (DTE).



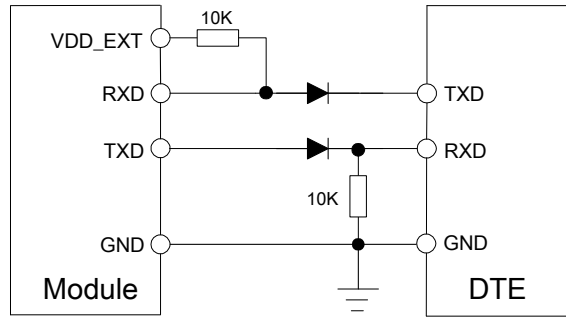
**Figure 20: Connection of the serial interfaces**

If the voltage level of UART is 3.3V at customer side, the following reference circuits are recommended for lower cost. If the voltage is 3.0V, please change the resistors in the following figure from 5.6K to 14K.



**Figure 21: Level converting by resistor**

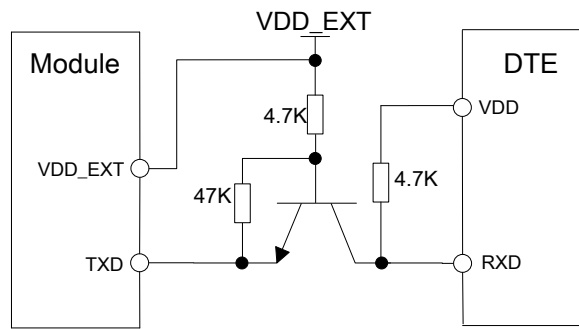
If the voltage of UART is 3V or 3.3V, users also can use following reference circuits:



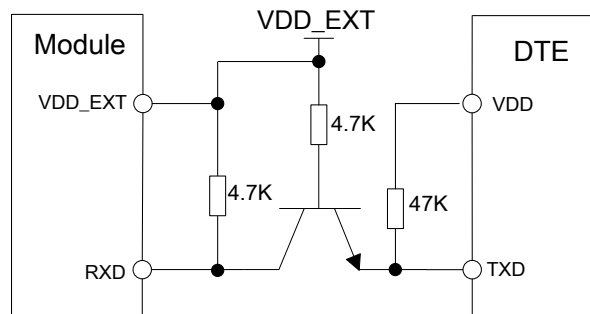
**Figure 22: Level converting by diodes**

*Note: when diode is used for level converting, customer should check the voltage drop on the diode to make sure the signal's voltage level could meet both module and DTE's electrical character. The recommend diode is Schottky diode e.g. RB551V-30TE-17 and SDM20U40.*

If the voltage of UART is 5V on customer side, users can use the following reference circuits:



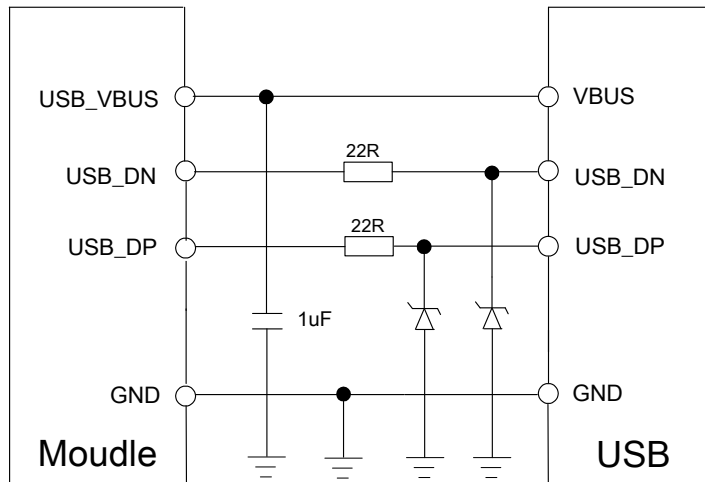
**Figure 23: TX level converting by transistor**



**Figure 24: RX level converting by transistor**

### 4.6.3 USB Interface

USB interface supports software debug function. When power on the module, connect VBUS, USB\_DP, USB\_DN and GND to PC, install the driver successfully, a com port could be recognized by PC, then customer could debug via this com port. The reference circuit is shown as below:



**Figure 25: USB reference circuit**

The maximum capacitance of TVS on USB data line should be less than 5pF (e.g. ESD9L5.0ST5G and ESD9M5.0ST5G). The USB\_DP and USB\_DN should be routed in differential traces.

*Note: please reserve USB interface or test point for debugging.*

**Table 10: VBUS characteristics**

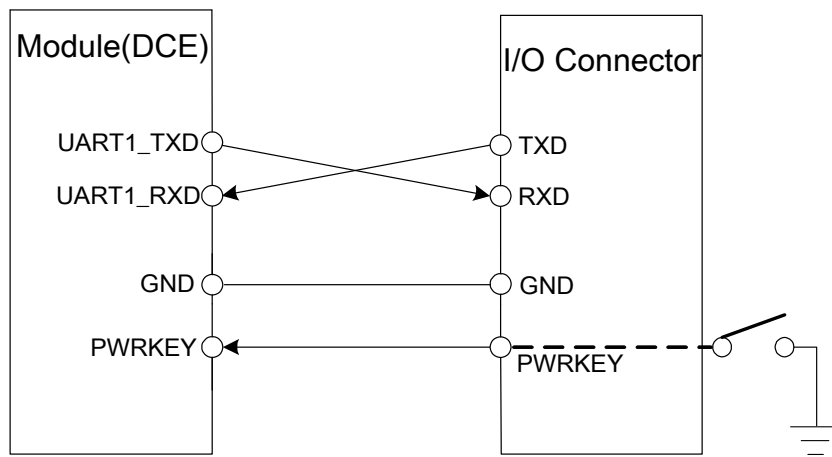
Pin	Min	Typ	Max	Unit
VBUS	4.3	5.0	7.0	V

#### 4.6.4 Software Upgrading and Debugging

Customer could upgrade module's firmware through USB or UART interface.

If upgrading through USB interface, it is necessary to power on SIM800A first, and then connect USB\_VBUS, USB\_DP, USB\_DN, and GND to PC. There is no need to operate PWRKEY pin in the whole procedure, when SIM800A detects USB\_VBUS and could communicate with USB\_DP and USB\_DN, it will enter USB download mode automatically.

If users upgrade the software through UART interface, it is recommended to lead the UART1\_TXD, UART1\_RXD, GND and PWRKEY pin to IO connector for the upgrading, and PWRKEY pin should connect to GND while upgrading. The reference connection is shown as below:



**Figure 26: Connection for software upgrading and debugging through UART**

UART interface does not support RS-232 level. When connect the module to the computer, the level shifter is needed.

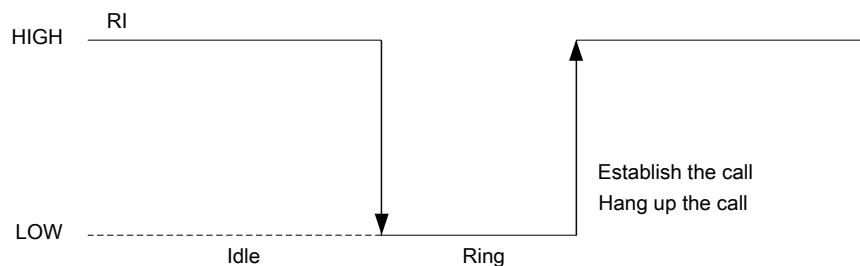
For more details about software upgrading, please refer to *document* <sup>[4]</sup>.

## 4.7 RI Behaviors

**Table 11: RI Behaviors**

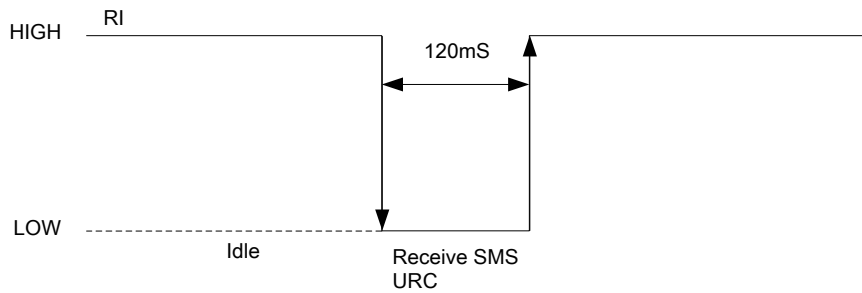
State	RI response
Standby	High
Receive Voice call	Changed to low. But when any of the following events occur, it will be changed to high: (1) Establish the call (2) Hang up the call
Receive SMS	Changed to low, and kept low for 120ms, then changed to high.
URC	When URC are reported, this pin will be changed to low, and kept low for 120ms, then changed to high. For more details, please refer to <i>document</i> <sup>[8]</sup> .

The behavior of the RI pin is shown in the following figure when the module is used as a receiver.



**Figure 27: RI behaviour of voice calling as a receiver**





**Figure 28: RI behaviour of URC or receive SMS**

However, if the module is used as caller, the RI will remain high. Please refer to the following figure:



**Figure 29: RI behaviour as a caller**

## 4.8 Audio Interfaces

SIM800A provides one analog input for electronic microphone and one analog output to drive 32Ω receiver.

**Table 12: Audio interface definition**

	Pin name	Pin number	Function
Audio channel	MICP	19	Audio input positive
	MICN	20	Audio input negative
	SPKP	21	Audio output positive
	SPKN	22	Audio output negative

“AT+CMIC” is used to adjust the input gain level of microphone.

“AT+CLVL” is used to adjust the output gain level.

“AT+SIDET” is used to set the side-tone level.

For more details about AT command, please refer to *document<sup>[1]</sup>* and *document<sup>[5]</sup>*.

In order to improve audio performance, the following reference circuits are recommended. The audio trace should be routed in differential and shielded by GND shown as below:

### 4.8.1 Speaker Reference Circuit

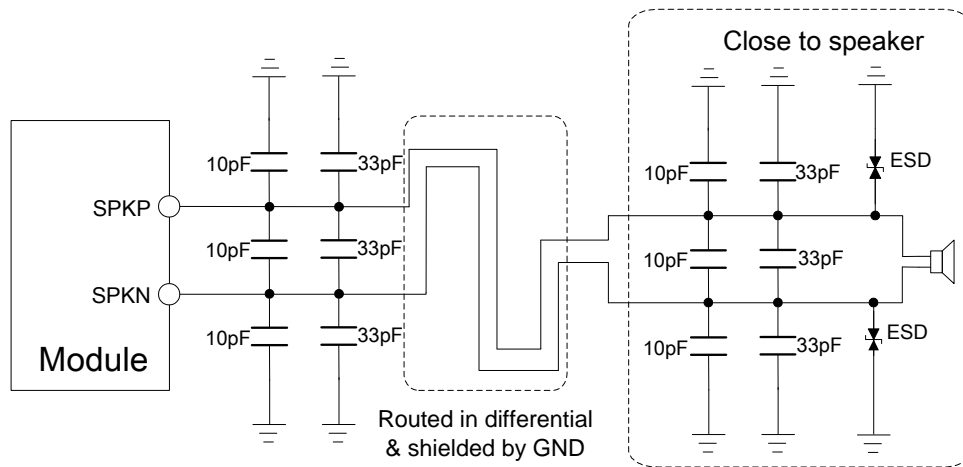


Figure 30: Speaker reference circuit

### 4.8.2 Microphone Reference Circuit

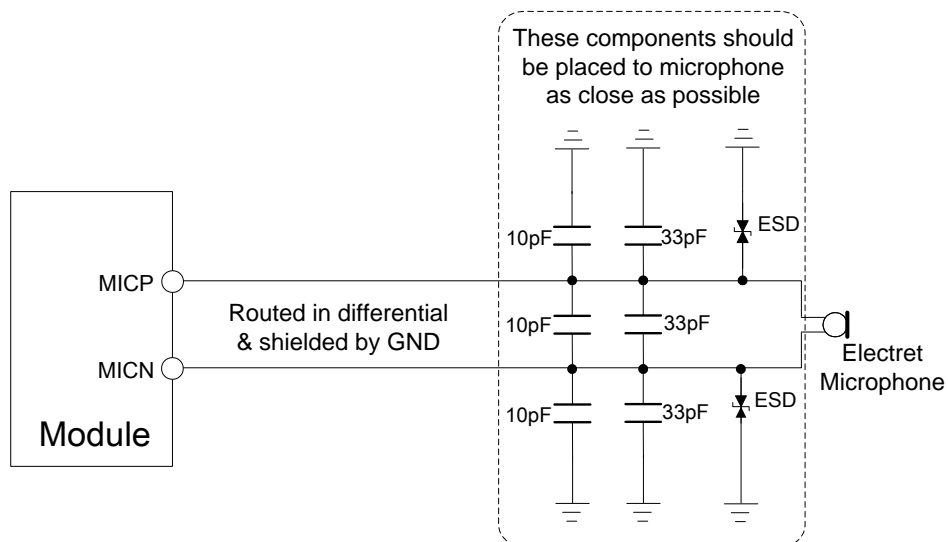


Figure 31 : Microphone reference circuit

### 4.8.3 Audio Electronic Characteristics

Table 13: Microphone Input Characteristics

Parameter	Min	Typ	Max	Unit
Mic biasing voltage	-	1.9	2.2	V
Working Current	-	-	2.0	mA
Input impedance(differential)	13	20	27	K $\Omega$

Idle channel noise		-	-	-67	dBm0
SINAD	Input level:-40dBm0	29	-	-	dB
	Input level:0dBm0	-	69	-	dB

**Table 14: Audio Output Characteristics**

parameter	Conditions	Min	Typ	Max	Unit
Normal output	$R_L=32\ \Omega$ receiver	-	15	90	mW

#### 4.8.4 TDD

Audio signal could be interfered by RF signal. Coupling noise could be filtered by adding 33pF and 10pF capacitor to audio lines. 33pF capacitor could eliminate noise from EGSM900MHz, while 10pF capacitor could eliminate noise from DCS1800Mhz frequency. Customer should develop this filter solution according to field test result.

GSM antenna is the key coupling interfering source of TDD noise. Thereat, pay attention to the layout of audio lines which should be far away from RF cable, antenna and VBAT pin. The bypass capacitor for filtering should be placed near module and another group needs to be placed near connector.

Conducting noise is mainly caused by the VBAT drop. If the audio PA was powered by VBAT directly, then there will be some cheep noise from speaker output easily. So it is better to put big capacitors and ferrite beads near audio PA input.

TDD noise has something to do with GND signal. If GND plane is not good, lots of high-frequency noises will interference microphone and speaker over bypass capacitor. So a good GND during PCB layout could avoid TDD noise.

## 4.9 SIM Card Interface

### 4.9.1 SIM Card Application

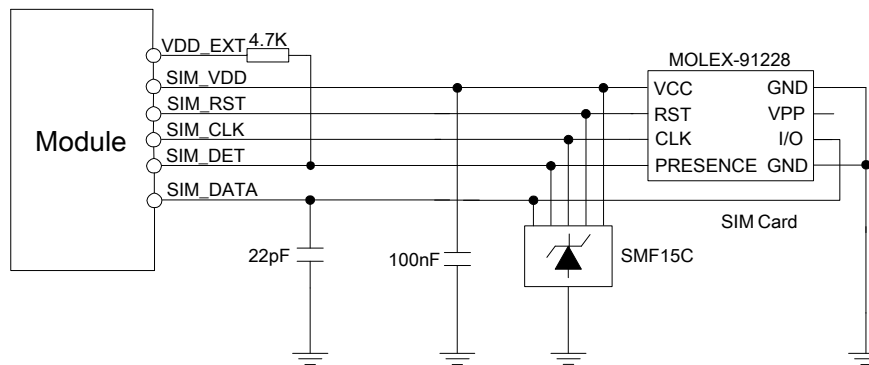
The SIM interface complies with the GSM Phase 1 specification and the new GSM Phase 2+ specification for FAST 64 kbps SIM card. Both 1.8V and 3.0V SIM card are supported.

**Table 15: SIM pin definition**

Pin name	Pin number	Function
SIM_VDD	18	Voltage supply for SIM card. Support 1.8V or 3V SIM card
SIM_DATA	15	SIM data input/output
SIM_CLK	16	SIM clock
SIM_RST	17	SIM reset

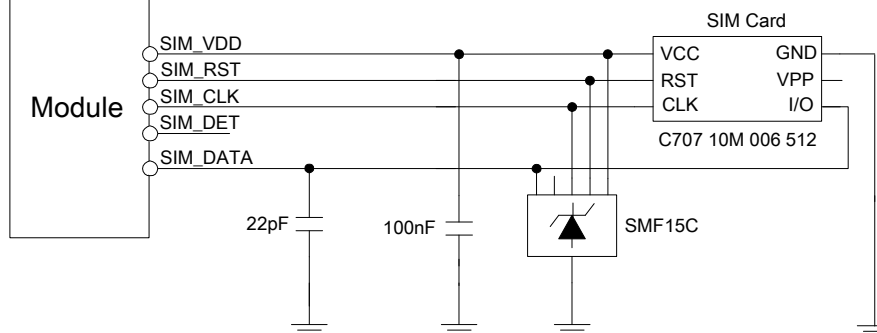
The SIM\_DET pin is used for SIM card detection. Users can select the 8-pin SIM card holder to implement this function. AT command “AT+CSDT” is used to enable or disable SIM card detection function. For details of this AT command, please refer to *document* <sup>[1]</sup>.

It is recommended to place an ESD protection component close to the SIM card holder, such as SMF15C provided by ON SEMI ([www.onsemi.com](http://www.onsemi.com)). The reference circuit of the 8-pin SIM card holder is illustrated as below:



**Figure 32: Reference circuit of the 8-pin SIM card holder**

If the SIM card detection function is not used, users can keep SIM\_DET pin open. The reference circuit of 6-pin SIM card holder is illustrated as below:



**Figure 33: Reference circuit of the 6-pin SIM card holder**

*Note: 51Ω series resistors are not needed for SIM\_RST/SIM\_CLK/SIM\_DATA, which are build-in already.*

#### 4.9.2 SIM Card Circuit Design Guide

SIM card signal could be interfered by the high speed signal, it is recommended to follow these guidelines while designing:

- SIM card holder should be far away from GSM antenna
- SIM traces should keep away from RF lines, VBAT and high-speed signal lines
- The traces should be as short as possible
- Keep SIM card holder’s GND connect to main ground directly

- Shielding the SIM card signal by ground well
- Recommended to place a 100nF capacitor on SIM\_VDD line and keep close to the SIM card holder
- Parasitic capacitance of TVS on SIM\_CLK/SIM\_DATA should less than 50pF

### 4.9.3 Design Considerations for SIM Card Holder

For 8 pins SIM card holder, SIMCom recommends to use Molex 91228. Customer can visit <http://www.molex.com> for more information about the holder.

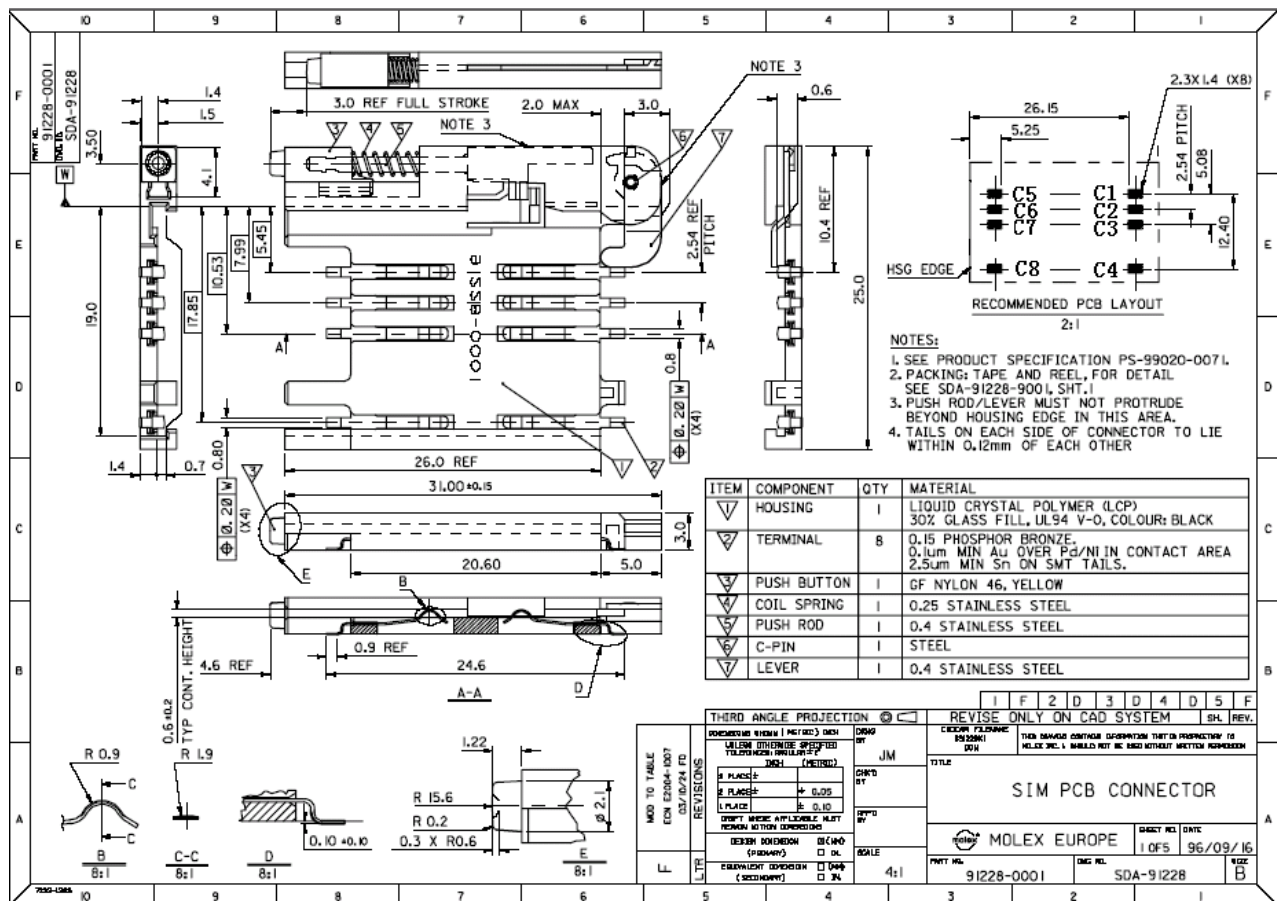


Figure 34: Molex 91228 SIM card holder

Table 16: Pin description (Molex SIM card holder)

Pin name	Signal	Description
C1	SIM_VDD	SIM card power supply
C2	SIM_RST	SIM card reset
C3	SIM_CLK	SIM card clock
C4	GND	Connect to GND
C5	GND	Connect to GND

C6	VPP	Not connect
C7	SIM_DATA	SIM card data I/O
C8	SIM_DET	Detect SIM card presence

For 6-pin SIM card holder, SIMCom recommends to use Amphenol C707 10M006 5122. Users can visit <http://www.amphenol.com> for more information about the holder.

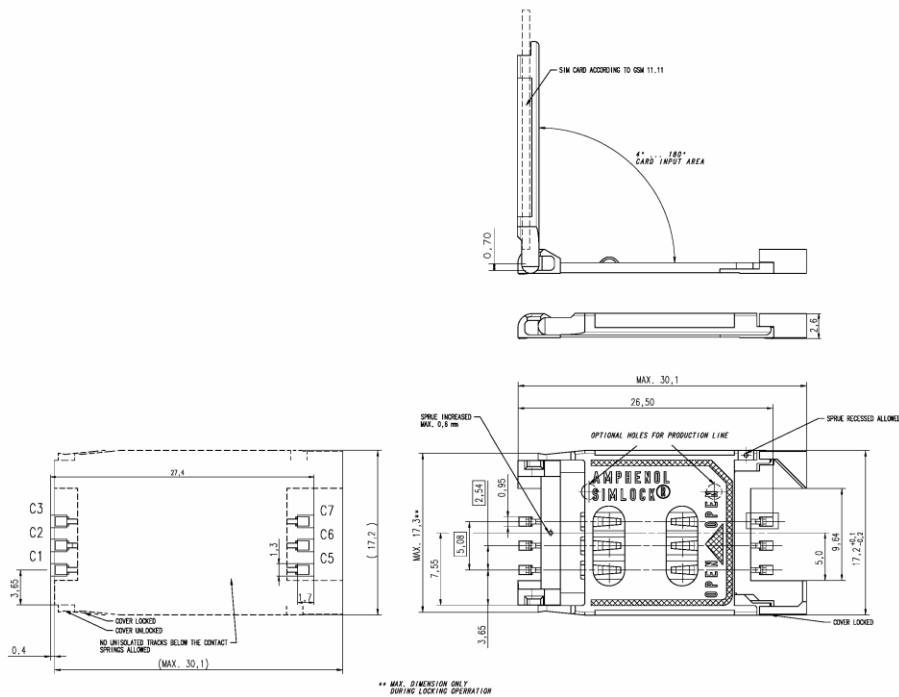


Figure 35: Amphenol C707 10M006 5122 SIM card holder

Table 17: Pin description (Amphenol SIM card holder)

Pin name	Signal	Description
C1	SIM_VDD	SIM card power supply
C2	SIM_RST	SIM card reset
C3	SIM_CLK	SIM card clock
C5	GND	Connect to GND
C6	VPP	Not connect
C7	SIM_DATA	SIM card data I/O

## 4.10 DISP Interface

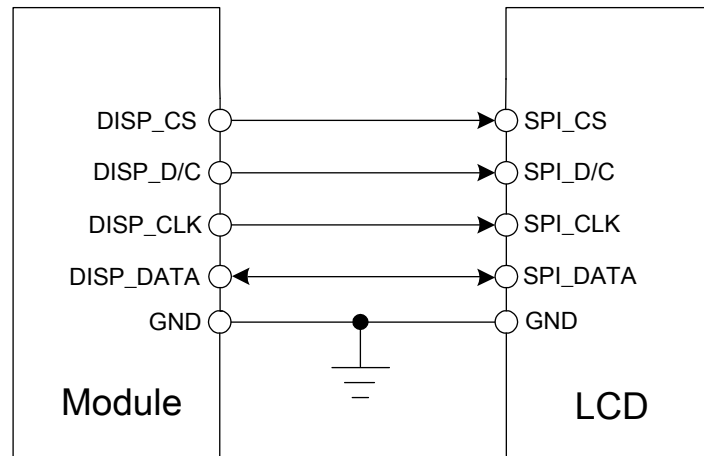
SIM800A provides a serial display interface.

Table 18: Pin definition of DISP interface

Pin name	Pin number	Description	Default function
----------	------------	-------------	------------------

DISP_CLK	11	Display clock	GPIO
DISP_DATA	12	Display data	GPIO
DISP_D/C	13	Data/command select	GPIO
DISP_CS	14	Chip select	GPIO

For the connection between LCD and SIM800A module, please refer to below figure:



**Figure 36: Connection of DISP interface**

*Note: DISP interface also can be used as SPI or PCM. If you need, please contact SIMCom.*

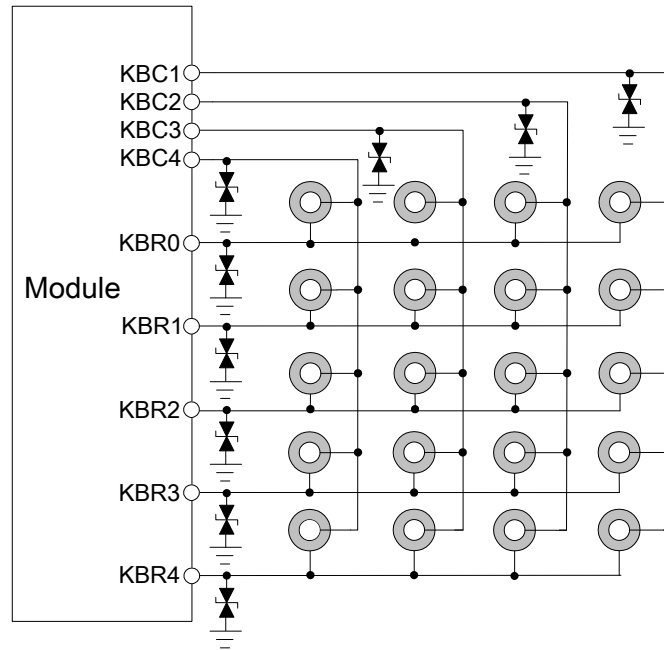
## 4.11 Keypad Interface

The keypad interface consists of 5 keypad column outputs and 4 keypad row inputs, supports total 20 keys.

**Table 19: Pin definition of the keypad interface**

Pin Name	Pin Number	Description	Default Function
KBR4	40	Keyboard Row 4	GPIO
KBR3	41	Keyboard Row 3	GPIO
KBR2	42	Keyboard Row 2	GPIO
KBR1	43	Keyboard Row 1	GPIO
KBR0	44	Keyboard Row 0	GPIO
KBC4	47	Keyboard Column 4	GPIO
KBC3	48	Keyboard Column 3	GPIO
KBC2	49	Keyboard Column 2	GPIO
KBC1	50	Keyboard Column 1	GPIO

*Note: keypad function is not supported in the standard firmware. If you need, please contact SIMCom.*



**Figure 37: Reference circuit of the keypad interface**

## 4.12 GPIO

SIM800A provides 3 GPIO, which could also be used as RF\_SYNC/JD and UART2.

For GPIO function, both output and input voltage level of the GPIO can be set by the AT command “AT+SGPIO” or “AT+CGPIO”. For more details, please refer to *document*<sup>[1]</sup>.

**Table 20: Pin definition of the GPIO**

Pin Name	Pin Number	Default Function	Default State
GPIO10	51	GPIO	Output, Pull down
GPIO11	67	GPIO	Output, Pull down
GPIO12	68	GPIO	Output, Pull down

*Note: Do not pull up GPIO11.*

## 4.13 I2C BUS

The SIM800A provides an I2C interface, which supports the master role and conforms to the I2C specification.

The features of I2C interface are listed as below:

- Compliant master mode operation
- Adjustable clock speed for F/S mode operation
- Support 7-bit/10-bit addressing
- Support high speed mode
- Support slave clock extension
- START/STOP/REPEATED condition
- Manual transfer mode
- Multi-bytes write per transfer (up to 8 data bytes for non-DMA mode)



- Multi-bytes read per transfer (up to 8 data bytes for non-DMA mode)
- Multi-transfer per transaction
- Combined format transfer with length change capability
- Active drive/write-and I/O configuration

**Table 21: Pin definition of the I2C**

Pin name	Pin number	Description	Default Function
SDA	37	I2C bus data	GPIO
SCL	38	I2C bus clock	GPIO

Note:

1. I2C has been pulled up to 2.8V via 4.7K $\Omega$  internally.
2. I2C function is not supported in the standard firmware. If you need, please contact SIMCom.

## 4.14 ADC

**Table 22: Pin definition of ADC**

Pin name	Pin number	Description
ADC	25	Analog to digital converter

SIM800A provides an auxiliary ADC, which can be used to measure the voltage. Users can use AT command “AT+CADC” to read the voltage value. For details about this AT command, please refer to *document* <sup>[1]</sup>.

**Table 23: ADC specification**

Parameter	Min	Typ	Max	Unit
Voltage range	0	-	2.8	V
ADC Resolution	-	10	-	bits
Sampling rate	-	-	1.0833	MHz
ADC precision	-	10	30	mV

## 4.15 Network Status Indication

**Table 24: Pin definition of the STATUS**

Pin name	Pin number	Description
NETLIGHT	52	Network status indication

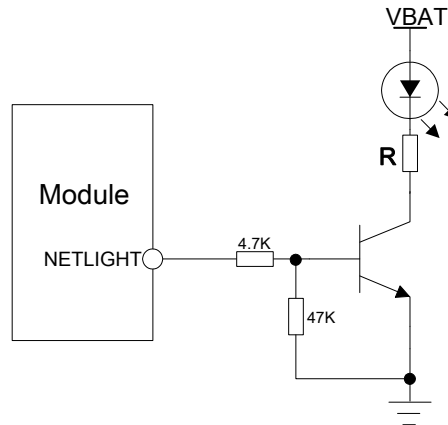
The NETLIGHT pin can drive one LED to indicate network status, which are listed in the following table:

**Table 25: Status of the NETLIGHT pin**

Status	SIM800A behavior
Off	Powered off
64ms On/ 800ms Off	Not registered to the network

64ms On/ 3000ms Off	Registered to the network
64ms On/ 300ms Off	GPRS communication is established

A reference circuit is recommended in the following figure:



**Figure 38: Reference circuit of NETLIGHT**

#### 4.16 Power on Status Indication

The STATUS pin indicates the power on status of module. The pin outputs high when module is powered on, outputs low when module is powered off.

**Table 26: Pin definition of the STATUS**

Pin name	Pin number	Description
STATUS	66	Power on status indication

#### 4.17 PWM

**Table 27: Pin definition of the PWM**

Pin name	Pin number	Description
PWM1	35	PWM1
PWM2	36	PWM2

PWM output frequency varies from 0 to 2KHz. Two 7-bit unsigned binary parameters are used for the output period and for the duty cycle. The AT command “AT + SPWM” is used to set the output period and duty cycle of the PWM. For details, please refer to *document* <sup>[1]</sup>.

A typical circuit of the PWM drives buzzer is shown in the following figure:

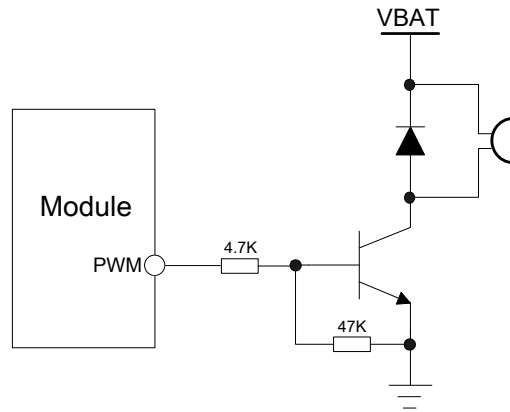


Figure 39: Reference circuit of PWM drive buzzer

Table 28: PWM output characteristics

Parameter	Min	Typ	Max	Unit
Working voltage	2.5	2.8	2.9	V
Working current		4	16	mA

Note: PWM pin must keep low when module is in the boot process.

#### 4.18 KPLED

SIM800A provides one open-drain LED driver pin.

Table 29: Pin definition of the KPLED

Pin name	Pin number	Description
KPLED	23	Sink current for keypad LED

Reference circuit is recommended in the following figure:

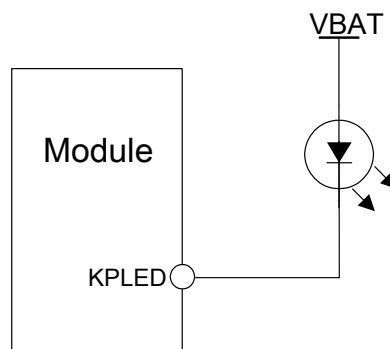


Figure 40: KPLED driver reference circuit

Table 30: KPLED specification

Pin name	Min	Typ	Max	Unit
KPLED	-	-	60	mA

## 4.19 Bluetooth

SIM800A supports Bluetooth function which can be operated by AT commands conveniently. For detail commands about Bluetooth please refer to *document* <sup>[1]</sup>

## 4.20 Antenna Interface

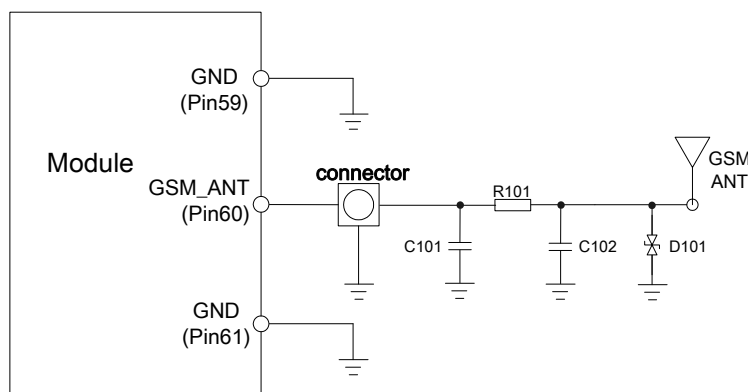
There are two antenna interfaces, GSM\_ANT and BT\_ANT.

- The input impedance of the antenna should be  $50\Omega$ , and the VSWR should be less than 2
- It is recommended that the GSM antenna and the BT antenna should be placed as far as possible
- The isolations of the two antenna should be bigger than 30dB

*Note: About the RF trace layout please refer to “AN\_SMT Module\_RF\_Reference\_Design\_Guide”*

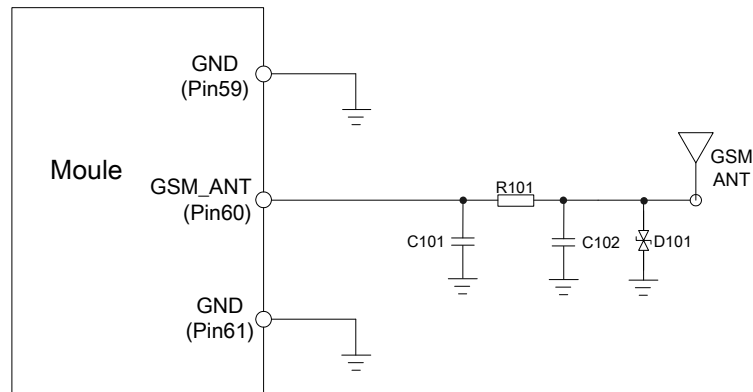
### 4.20.1 GSM Antenna Interface

There is a GSM antenna pad named GSM\_ANT to connect a GSM antenna, the connection of the antenna must be decoupled from DC voltage. This is necessary because the antenna connector is DC coupled to ground via an inductor for ESD protection. The GSM antenna must be matched properly to achieve the best performance, so the matching circuit is necessary. For the purpose of static electricity, we recommend to add D101, which is a TVS, the recommendation ESD component as table 31. The connection is recommended as following:



**Figure 41: GSM antenna matching circuit**

R101, C101, C102 are the matching circuit, the values depend on antenna debug result. Normally R101 is  $0\Omega$ , C101 and C102 are not mounted. The RF connector is used for conducted test. If the space between GSM\_ANT pin and antenna is not enough, the matching circuit could be simplified as the following figure:



**Figure 42: GSM simple antenna matching circuit**

For the purpose of static electricity, we recommend to add D101, which is a TVS, the recommendation ESD component as table 31.

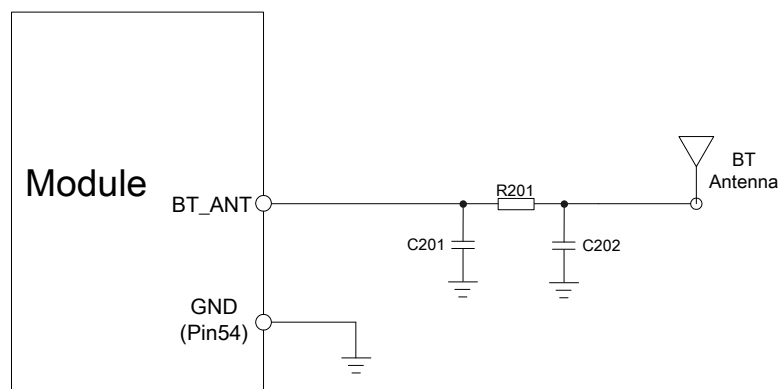
Normally R101 is  $0\Omega$ ; C101 and C102 are not mounted.

**Table 31: Recommended TVS for GSM Antenna Interface**

Package	Part Number	Supplier
0201	LXES03AAA1-154	MuRata
0402	LXES15AAA1-153	MuRata

#### 4.20.2 Bluetooth Antenna Interface

For Bluetooth antenna, it is recommended to reserve the matching circuit as following:



**Figure 43: Bluetooth antenna matching circuit**

R201, C201, C202 are the matching circuit, the values depend on antenna debug result. Normally R201 is  $0\Omega$ , C201 and C202 are not mounted.

There are some suggestions for placing components and RF trace for GSM\_ANT/BT\_ANT:

- The RF connector is used for conducted test, so keep it as close to pin GSM\_ANT as possible
- Antenna matching circuit should be close to the antenna
- Keep the RF traces impedance as  $50\Omega$

- The RF traces should be kept far away from the high frequency signals and strong interference source

## 5 PCB Layout

Usually, most electronic products with good performance are based on good PCB layout. Poor PCB layout will lead to lots of issues, like TDD noise, SIM card undetected, etc. The final solution for these problems is to redo PCB layout. Making good PCB layout will save developing schedule and cost as well.

This section will give some guidelines on PCB layout to eliminate interfere or noise by greatest degree, and save product development period.

### 5.1 PIN Assignment

Before the placement of the PCB design, customer should learn well about PIN assignment in order to get reasonable layout with so many external components. Please refer to the figure below:

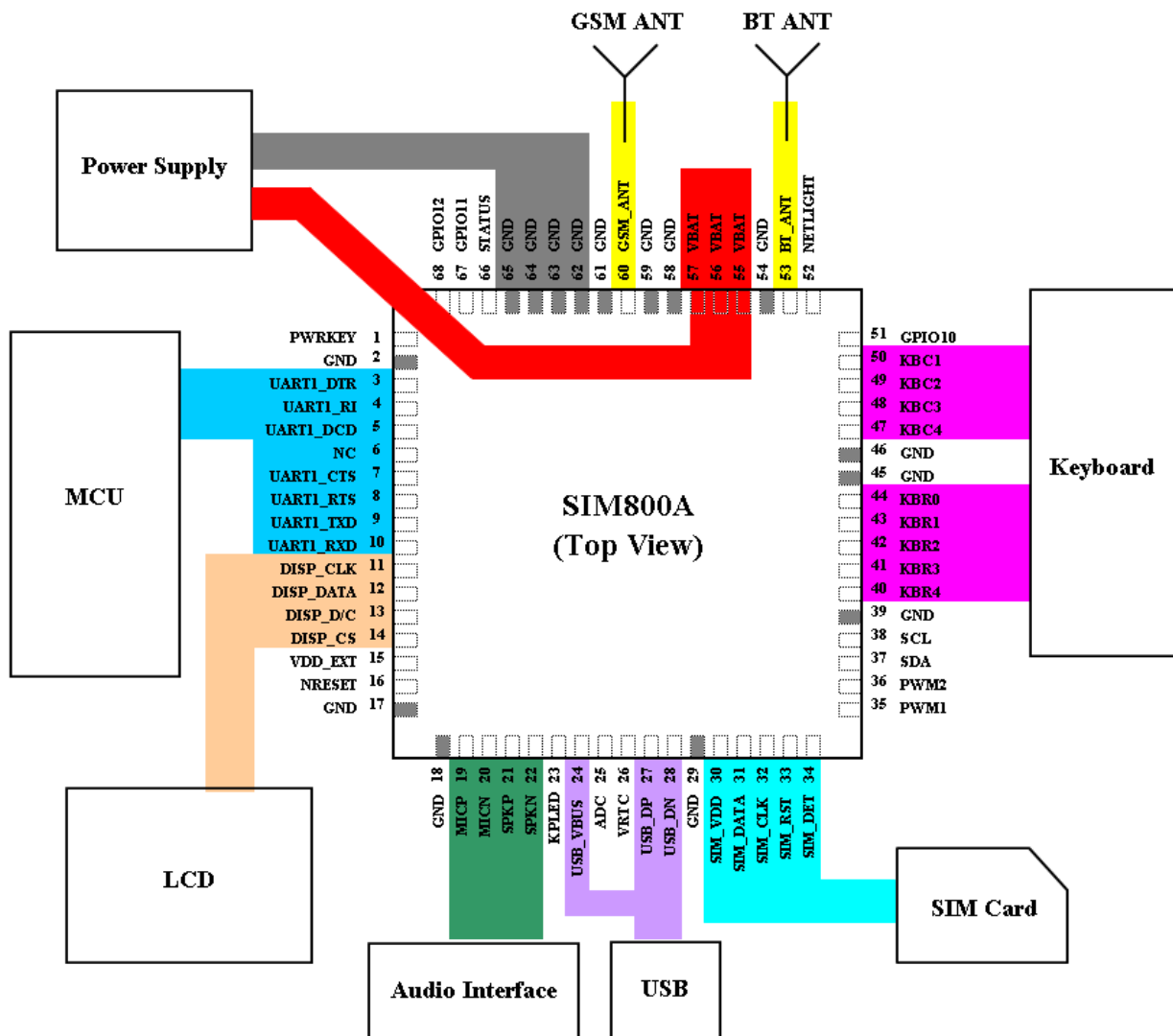


Figure 44: Pin assignment

## 5.2 Principle of PCB Layout

During layout, we should pay attention to the following interfaces, such as Antenna, power supply, SIM card interface, audio interface and so on.

### 5.2.1 Antenna

- The length of trace between pin output and connector should be as short as possible
- Do not trace RF signal across the whole board
- The RF signal should be far away from SIM card, power ICs

### 5.2.2. Power Supply

- Both VBAT and return GND should be as short and wide as possible
- The current should go through Zener diode, capacitors, then VBAT pins

### 5.2.3 SIM Card Interface

- SIM card holder has no anti-EMI component inside. Thus SIM card interface maybe interfered, please pay more attention on this interface during layout
- Ensure SIM card holder is far away from antenna or RF cable inside
- Put SIM card holder near the module, as nearer as possible
- Add ESD component to protect SIM\_CLK, SIM\_DATA, SIM\_RST and SIM\_VDD signals which should be far away from power and high-speed-frequency signal

### 5.2.4 Audio Interface

- The signal trace of audio should far away from antenna and power
- The audio signal should avoid to parallel with VBAT trace

### 5.2.5 Others

- It is better to trace signal lines of UART bunched, as well as signals of USB.



## 6 Electrical, Reliability and Radio Characteristics

### 6.1 Absolute Maximum Ratings

The absolute maximum ratings stated in following table are stress ratings under non-operating conditions. Stresses beyond any of these limits will cause permanent damage to SIM800A.

**Table 32: Absolute maximum ratings**

Symbol	Parameter	Min	Typ	Max	Unit
V <sub>BAT</sub>	V <sub>BAT</sub> power supply voltage	-0.3	-	4.5	V
V <sub>BUS</sub>	USB power supply voltage	-0.3	-	7.0	V
I <sub>I</sub>	Digital interface input current	-	4	16	mA
I <sub>O</sub>	Digital interface output current	-	4	16	mA

### 6.2 Recommended Operating Conditions

**Table 33: Recommended operating conditions**

Symbol	Parameter	Min	Typ	Max	Unit
V <sub>BAT</sub>	Power supply voltage	3.4	4.0	4.4	V
T <sub>OPER</sub>	Operating temperature	-40	+25	+85	°C
T <sub>STG</sub>	Storage temperature	-45	-	+90	°C

### 6.3 Digital Interface Characteristics

**Table 34: Digital interface characteristics**

Symbol	Parameter	Min	Typ	Max	Unit
V <sub>IH</sub>	High-level input voltage	2.4	-	-	V
V <sub>IL</sub>	Low-level input voltage	-	-	0.4	V
V <sub>OH</sub>	High-level output voltage	2.7	-	-	V
V <sub>OL</sub>	Low-level output voltage	-	-	0.1	V

*Note: These parameters are for digital interface pins, such as keypad, GPIO, I2C, UART, LCD, and PWM.*

### 6.4 SIM Card Interface Characteristics

**Table 35: SIM card interface characteristics**

Symbol	Parameter	Min	Typ	Max	Unit
I <sub>IH</sub>	High-level input current	-10	-	10	uA
I <sub>IL</sub>	Low-level input current	-10	-	10	uA
V <sub>IH</sub>	High-level input voltage	1.4	-	-	V

		2.4	-	-	V
$V_{IL}$	Low-level input voltage	-	-	0.4	V
				2.4	V
$V_{OH}$	High-level output voltage	1.7	-	-	V
		2.7	-	-	V
$V_{OL}$	Low-level output voltage	-	-	0.1	V
		-	-	0.1	V

## 6.5 SIM\_VDD Characteristics

Table 36: SIM\_VDD characteristics

Symbol	Parameter	Min	Typ	Max	Unit
$V_O$	Output voltage	2.75	2.9	3.00	V
		1.65	1.80	1.95	
$I_O$	Output current	-	-	10	mA

## 6.6 VDD\_EXT Characteristics

Table 37: VDD\_EXT characteristics

Symbol	Parameter	Min	Typ	Max	Unit
$V_O$	Output voltage	2.70	2.80	2.95	V
$I_O$	Output current	-	-	10	mA

## 6.7 VRTC Characteristics

Table 38: VRTC characteristics

Symbol	Parameter	Min	Typ	Max	Unit
$V_{RTC-IN}$	VRTC input voltage	2.00	3.00	3.15	V
$I_{RTC-IN}$	VRTC input current	-	2	-	$\mu$ A
$V_{RTC-OUT}$	VRTC output voltage	-	3.00	-	V
$I_{RTC-OUT}$	VRTC output current	-	10	-	$\mu$ A

## 6.8 Current Consumption (VBAT = 4V)

**Table 39: Current consumption**

Symbol	Parameter	Conditions	Min	Typ	Max	Unit
VBAT	Voltage			4.0		V
	Power drop	PCL=5			350	mV
	Voltage ripple	PCL=5 @ f<200kHz @ f>200kHz			50	
				2.0		mV
I <sub>VBAT</sub>	Average current	Power down mode		130		uA
		Sleep mode (AT+CFUN=1): ( BS-PA-MFRMS=9 ) ( BS-PA-MFRMS=5 ) ( BS-PA-MFRMS=2 )		0.85		mA
				0.95		mA
				1.30		mA
		Idle mode (AT+CFUN=1): EGSM900 DCS1800		12.1		mA
				12.1		mA
		Voice call (PCL=5): EGSM900 Voice call (PCL=0): DCS1800		217		mA
				137		mA
		Data mode GPRS (1Rx,4Tx): EGSM900 DCS1800		408		mA
				281		mA
Data mode GPRS (3Rx,2Tx): EGSM900 DCS1800		347		mA		
		218		mA		
Data mode GPRS (4Rx,1Tx): EGSM900 DCS1800		231		mA		
		156		mA		
I <sub>MAX</sub>	Peak current	During TX burst			2.0	A

*Note: The data above are the typical value tested in laboratory. In the mass production stage, there are differences among each individual.*

## 6.9 Electro-Static Discharge

SIM800A is an ESD sensitive component, so more attention should be paid to the procedure of handling and packaging. The ESD characteristics are shown in the following table:

**Table 40: The ESD characteristics (Temperature: 25°C, Humidity: 45 %)**

Pin	Contact discharge	Air discharge
VBAT	±6KV	±12KV
GND	±6KV	±12KV
UART1_RXD/TXD	±4KV	±8KV
Antenna port	±6KV	±12KV
SPKP/ SPKN MICP/ MICN	±3KV	±6KV
PWRKEY	±4KV	±8KV

## 6.10 Radio Characteristics

### 6.10.1 Module RF Output Power

The following table shows the module conducted output power, it is followed by the 3GPP TS 05.05 technical specification requirement:

**Table 41: EGSM 900 conducted RF output power**

EGSM 900			
PCL	Nominal output power (dBm)	Tolerance (dB) for conditions	
		Normal	Extreme
0-2	39	±2	±2.5
3	37	±3	±4
4	35	±3	±4
5	33	±3	±4
6	31	±3	±4
7	29	±3	±4
8	27	±3	±4
9	25	±3	±4
10	23	±3	±4
11	21	±3	±4
12	19	±3	±4
13	17	±3	±4
14	15	±3	±4
15	13	±3	±4
16	11	±5	±6
17	9	±5	±6
18	7	±5	±6
19-31	5	±5	±6

**Table 42: DCS 1800 conducted RF output power**

DCS 1800			
PCL	Nominal output power (dBm)	Tolerance (dB) for conditions	
		Normal	Extreme
29	36	±2	±2.5
30	34	±3	±4
31	32	±3	±4
0	30	±3	±4
1	28	±3	±4
2	26	±3	±4
3	24	±3	±4
4	22	±3	±4
5	20	±3	±4
6	18	±3	±4
7	16	±3	±4
8	14	±3	±4
9	12	±4	±5
10	10	±4	±5
11	8	±4	±5
12	6	±4	±5
13	4	±4	±5
14	2	±5	±6
15-28	0	±5	±6

### 6.10.2 Module RF Receive Sensitivity

The following table shows the module's conducted receive sensitivity, it is tested under static condition:

**Table 43: Conducted RF receive sensitivity**

Frequency	Receive sensitivity (Typical)	Receive sensitivity(Max)
EGSM900	-109dBm	-107dBm
DCS1800	-109dBm	-107dBm

### 6.10.3 Module Operating Frequencies

The following table shows the module's operating frequency range, it is followed by the 3GPP TS 05.05 technical specification requirement.

**Table 44: Operating frequencies**

Frequency	Receive	Transmit
EGSM900	925 ~ 960MHz	880 ~ 915MHz
DCS1800	1805 ~ 1880MHz	1710 ~ 1785MHz

## 7 Manufacturing

### 7.1 Top and Bottom View of SIM800A



Figure 45: Top and bottom view of SIM800A

### 7.2 Typical Solder Reflow Profile

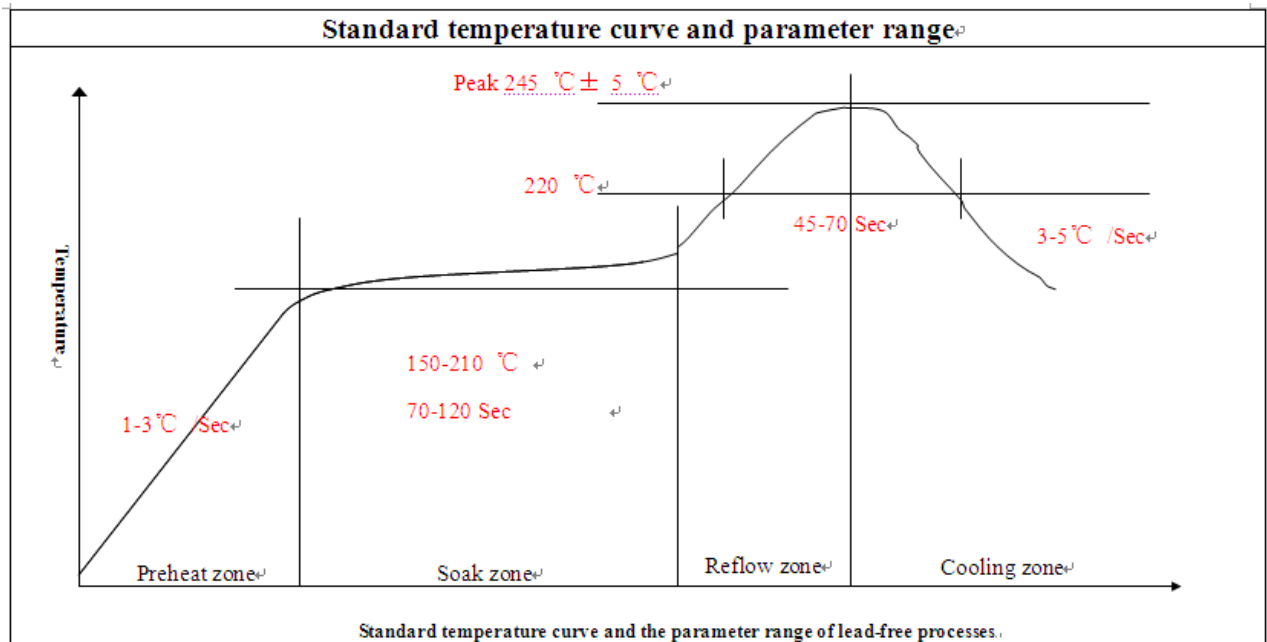


Figure 46: Typical Solder Reflow Profile

Note: Please refer to “Module secondary-SMT-UGD” for more information about the module shipping and manufacturing.

### 7.3 The Moisture Sensitivity Level

The moisture sensitivity level of SIM800 is 3. The module should be mounted within 168 hours after unpacking in the environmental conditions of temperature  $<30\text{ }^{\circ}\text{C}$  and relative humidity of  $<60\%$  (RH). It is necessary to bake the module if the above conditions are not met.

**Table 45: Moisture classification level and floor life**

Level	Floor Life (out of bag) at factory ambient $\leq 30\text{ }^{\circ}\text{C}$ /60% RH or as stated
1	Unlimited at $\leq 30\text{ }^{\circ}\text{C}$ /85% RH
2	1 year
2a	4 weeks
3	168 hours
4	72 hours
5	48 hours
5a	24 hours
6	Mandatory bake before use. After bake, it must be reflowed within the time limit specified on the label.

*Note:*

1. *If the vacuum package is not open for 6 months or longer than the packing date, baking is also recommended before re-flow soldering.*
2. *For product handling, storage, processing, IPC / JEDEC J-STD-033 must be followed.*

### 7.4 Baking Requirements

Because of its sensitivity to moisture absorption, SIM800 should be baked sufficiently before re-flow soldering. Otherwise SIM800 will be at the risk of permanent damage during re-flow soldering. SIM800 should be baked 192 hours at temperature  $40\text{ }^{\circ}\text{C} \pm 5\text{ }^{\circ}\text{C} / -0\text{ }^{\circ}\text{C}$  and  $<5\%$  RH for low-temperature device containers, or 72 hours at temperature  $80\text{ }^{\circ}\text{C} \pm 5\text{ }^{\circ}\text{C}$  for high-temperature device containers. Note that the plastic tray is not heat resistant, so SIM800 modules should be taken out for baking, otherwise the tray may be damaged by high-temperature during baking.

**Table 46: Baking requirements**

Baking temperature	Moisture	Time
$40\text{ }^{\circ}\text{C} \pm 5\text{ }^{\circ}\text{C}$	$<5\%$	192 hours
$120\text{ }^{\circ}\text{C} \pm 5\text{ }^{\circ}\text{C}$	$<5\%$	4 hours

## 8. Appendix

### I. Related Documents

**Table 47: Related Documents**

SN	Document name	Remark
[1]	SIM800 Series_AT Command Manual	
[2]	ITU-T Draft new recommendation V.25ter:	Serial asynchronous automatic dialing and control
[3]	GSM 07.07:	Digital cellular telecommunications (Phase 2+); AT command set for GSM Mobile Equipment (ME)
[4]	GSM 07.10:	Support GSM 07.10 multiplexing protocol
[5]	GSM 07.05:	Digital cellular telecommunications (Phase 2+); Use of Data Terminal Equipment – Data Circuit terminating Equipment (DTE – DCE) interface for Short Message Service (SMS) and Cell Broadcast Service (CBS)
[6]	GSM 11.14:	Digital cellular telecommunications system (Phase 2+); Specification of the SIM Application Toolkit for the Subscriber Identity Module – Mobile Equipment (SIM – ME) interface
[7]	GSM 11.11:	Digital cellular telecommunications system (Phase 2+); Specification of the Subscriber Identity Module – Mobile Equipment (SIM – ME) interface
[8]	GSM 03.38:	Digital cellular telecommunications system (Phase 2+); Alphabets and language-specific information
[9]	GSM 11.10	Digital cellular telecommunications system (Phase 2); Mobile Station (MS) conformance specification; Part 1: Conformance specification
[10]	AN_Serial Port	AN_Serial Port
[11]	AN_SIM900_TCPIP	TCP/IP Applications User Manual
[12]	Module secondary-SMT-UGD	
[13]	AN_SMT Module_RF_Reference Design_Guide	
[14]	SIM800_EVB kit_User Guide_VX.XX	



## II. Terms and Abbreviations







**Table 48: Terms and Abbreviations**

Abbreviation	Description
ADC	Analog-to-Digital Converter
AMR	Adaptive Multi-Rate
BT	Bluetooth
CS	Coding Scheme
CSD	Circuit Switched Data
CTS	Clear to Send
DTE	Data Terminal Equipment (typically computer, terminal, printer)
DTR	Data Terminal Ready
DTX	Discontinuous Transmission
EFR	Enhanced Full Rate
EGSM	Enhanced GSM
ESD	Electrostatic Discharge
ETS	European Telecommunication Standard
FR	Full Rate
GPRS	General Packet Radio Service
GSM	Global Standard for Mobile Communications
HR	Half Rate
IMEI	International Mobile Equipment Identity
Li-ion	Lithium-Ion
MO	Mobile Originated
MS	Mobile Station (GSM engine), also referred to as TE
MT	Mobile Terminated
PAP	Password Authentication Protocol
PBCCH	Packet Broadcast Control Channel
PCB	Printed Circuit Board
PCL	Power Control Level
PCS	Personal Communication System, also referred to as GSM 1900
PDU	Protocol Data Unit
PPP	Point-to-point protocol
RF	Radio Frequency
RMS	Root Mean Square (value)
RTC	Real Time Clock
RX	Receive Direction
SIM	Subscriber Identification Module
SMS	Short Message Service
TDD	Time Division Distortion
TE	Terminal Equipment, also referred to as DTE

TX	Transmit Direction
UART	Universal Asynchronous Receiver & Transmitter
URC	Unsolicited Result Code
USSD	Unstructured Supplementary Service Data
VSWR	Voltage Standing Wave Ratio
<b>Phonebook abbreviations</b>	
FD	SIM fix dialing phonebook
LD	SIM last dialing phonebook (list of numbers most recently dialed)
MC	Mobile Equipment list of unanswered MT calls (missed calls)
ON	SIM (or ME) own numbers (MSISDNs) list
RC	Mobile Equipment list of received calls
SM	SIM phonebook
NC	Not connect

### III.Safety Caution

**Table 49: Safety caution**

Marks	Requirements
	When in a hospital or other health care facility, observe the restrictions about the use of mobiles. Switch the cellular terminal or mobile off, medical equipment may not operate normally because of RF energy interference.
	Switch off the cellular terminal or mobile before boarding an aircraft. Make sure it is switched off. The operation of wireless appliances in an aircraft is forbidden to prevent interference with communication systems. Forget to think much of these instructions may lead to flight safety or offend against local legal action, or both.
	Do not operate the cellular terminal or mobile in the presence of flammable gases or fumes. Switch off the cellular terminal when you are near petrol stations, fuel depots, chemical plants or where blasting operations are in progress. Operation of any electrical equipment in potentially explosive atmospheres can constitute a safety hazard.
	Your cellular terminal or mobile receives and transmits radio frequency energy while switched on. RF interference can occur if it is used close to TV sets, radios, computers or other electric equipment.
	Road safety comes first! Do not use a hand-held cellular terminal or mobile when driving a vehicle, unless it is securely mounted in a holder for hands free operation. Before making a call with a hand-held terminal or mobile, park the vehicle.
	<p>GSM cellular terminals or mobiles operate over radio frequency signals and cellular networks and cannot be guaranteed to connect in all conditions, for example, no mobile fee or an invalid SIM card. While you are in this condition and need emergent help, please remember using emergency calls. In order to make or receive calls, the cellular terminal or mobile must be switched on and in a service area with adequate cellular signal strength.</p> <p>Some networks do not allow emergency calls if certain network services or phone features are in use (e.g. lock functions, fixed dialing, etc.). You may have to deactivate those features before you can make an emergency call.</p> <p>Also, some networks require that a valid SIM card be properly inserted in the cellular terminal or mobile.</p>

**Contact us:**

**Shanghai SIMCom Wireless Solutions Ltd.**

Add: SIM Technology Building, No. 633, Jinzhong Road, Changning District, Shanghai P.R. China  
200335

Tel: 86-21-32523300

Fax: 86-21-32523020

Email: [simcom@sim.com](mailto:simcom@sim.com)

Website: [www.simcomm2m.com](http://www.simcomm2m.com)