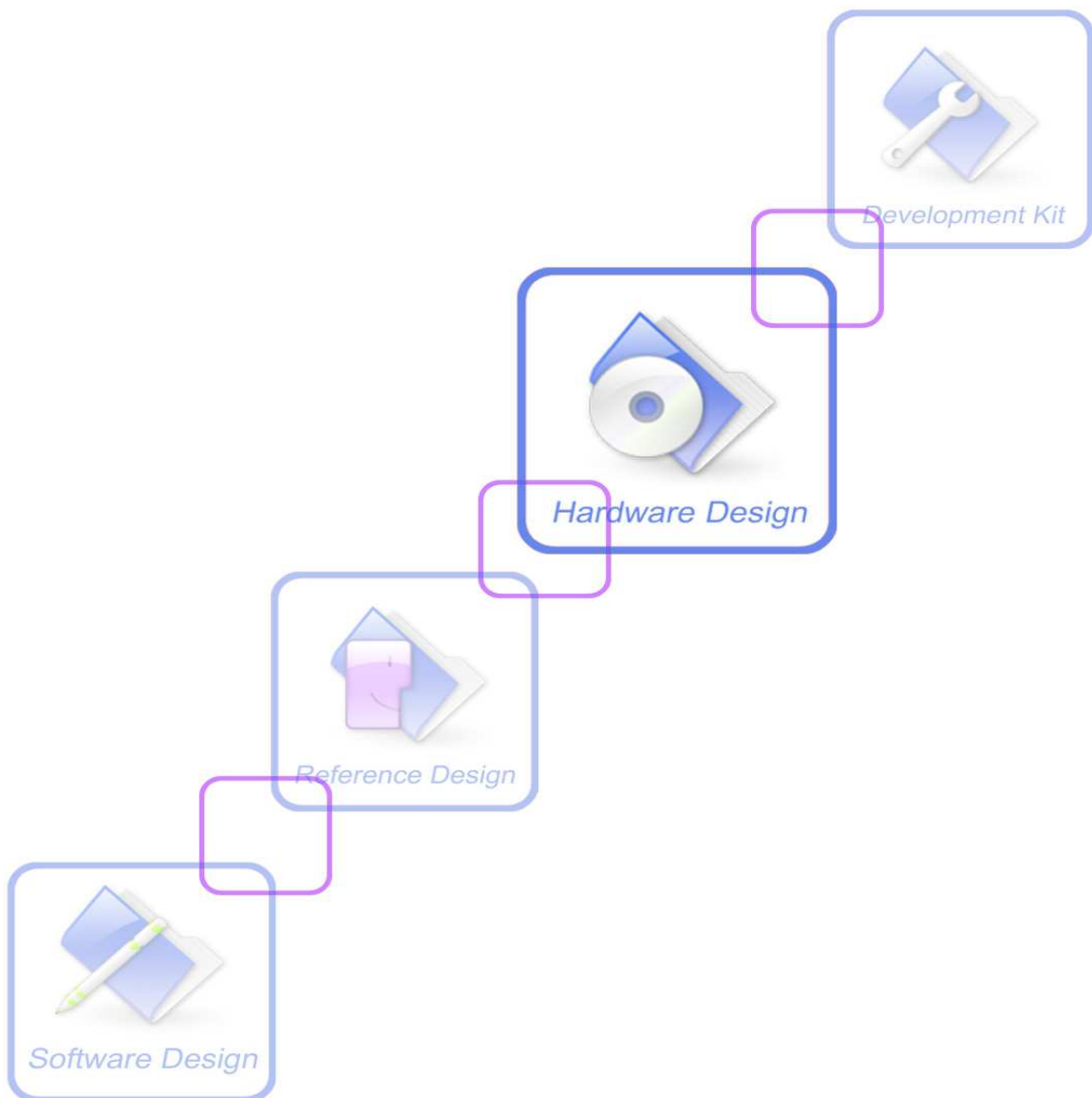




A company of SIM Tech

# SIM800C\_Hardware\_Design\_V1.03



<b>Document Title</b>	SIM800C Hardware Design
<b>Version</b>	V1.03
<b>Date</b>	2015-10-20
<b>Status</b>	Release
<b>Document Control ID</b>	SIM800C_Hardware_Design_V1.03

### General Notes

SIMCom offers this information as a service to its customers, to support application and engineering efforts that use the products designed by SIMCom. The information provided is based upon requirements specifically provided to SIMCom by the customers. SIMCom has not undertaken any independent search for additional relevant information, including any information that may be in the customer's possession. Furthermore, system validation of this product designed by SIMCom within a larger electronic system remains the responsibility of the customer or the customer's system integrator. All specifications supplied herein are subject to change.

### Copyright

This document contains proprietary technical information which is the property of SIMCom Limited, copying of this document and giving it to others and the using or communication of the contents thereof, are forbidden without express authority. Offenders are liable to the payment of damages. All rights reserved in the event of grant of a patent or the registration of a utility model or design. All specification supplied herein are subject to change without notice at any time.

*Copyright © Shanghai SIMCom Wireless Solutions Ltd. 2015*

# Contents

<b>Version History</b> .....	<b>8</b>
<b>1. Introduction</b> .....	<b>9</b>
<b>2. SIM800C Overview</b> .....	<b>9</b>
2.1. SIM800C.....	9
2.2. SIM800C Key Features.....	9
2.3. Operating Mode .....	11
2.4. Functional Diagram.....	12
<b>3. Package Information</b> .....	<b>13</b>
3.1. Pin Out Diagram .....	13
3.2. Pin Description.....	13
3.3. Package Dimensions .....	15
<b>4. Application Interface</b> .....	<b>17</b>
4.1. Power Supply .....	17
4.1.1. Power Supply Pin.....	18
4.1.2. Monitoring Power Supply .....	19
4.2. Power on/off SIM800C.....	19
4.2.1. Power on SIM800C.....	19
4.2.2. Power off SIM800C .....	20
4.3. Power Saving Mode .....	22
4.3.1. Minimum Functionality Mode .....	22
4.3.2. Sleep Mode 1 (AT+CSCLK=1) .....	22
4.3.3. Wake Up SIM800C from Sleep Mode 1 .....	23
4.3.4. Sleep Mode 2 (AT+CSCLK=2) .....	23
4.3.5. Wake Up SIM800C from Sleep Mode 2.....	23
4.4. Power Saving Mode .....	23
4.5. Serial Port and USB Interface .....	24
4.5.1. Function of Serial Port .....	25
4.5.2. Serial Interfaces.....	25
4.5.3. Debug Interface.....	27
4.5.4. Software Upgrade.....	28
4.6. UART1_RI Behaviors.....	28
4.7. Audio Interfaces .....	29
4.7.1. Speaker Interfaces Configuration.....	30
4.7.2. Microphone Interfaces Configuration .....	30
4.7.3. Audio Electronic Characteristic .....	30
4.7.4. TDD .....	31
4.8. SIM Card Interface.....	31
4.8.1. SIM Card Application .....	31

4.8.2.	SIM Card Design Guide .....	32
4.8.3.	Design Considerations for SIM Card Holder .....	32
4.9.	ADC .....	34
4.10.	Network Status Indication.....	35
4.10.1.	NETLIGHT Multiplexing Function.....	35
4.11.	Operating Status Indication.....	36
4.11.1.	STATUS Multiplexing Function .....	36
4.12.	RF Synchronization Signal .....	36
4.12.1.	RF_SYNC Multiplexing Function.....	36
4.13.	Antenna Interface .....	37
4.13.1	GSM Antenna Interface .....	37
4.13.2	Bluetooth Antenna Interface .....	38
<b>5.</b>	<b>PCB Layout .....</b>	<b>39</b>
5.1	Pin Assignment .....	39
5.2	Principle of PCB Layout .....	39
5.2.1	Antenna Interface .....	40
5.2.2	Power Supply .....	40
5.2.3	SIM Card Interface.....	40
5.2.4	Audio Interface.....	40
5.2.5	Others .....	40
<b>6.</b>	<b>Electrical, Reliability and Radio Characteristics .....</b>	<b>41</b>
6.1	Absolute Maximum Ratings .....	41
6.2	Recommended Operating Conditions .....	41
6.3	Digital Interface Characteristics.....	41
6.4	SIM Card Interface Characteristics.....	41
6.5	SIM_VDD Characteristics .....	42
6.6	VDD_EXT Characteristics.....	42
6.7	VRTC Characteristics .....	42
6.8	Current Consumption (VBAT=4.0V) .....	42
6.9	Electro-Static Discharge.....	43
6.10	Radio Characteristics .....	44
6.10.1	Module RF Output Power.....	44
6.10.2	Module RF Receive Sensitivity .....	45
6.10.3	Module Operating Frequencies.....	45
<b>7.</b>	<b>Manufacturing .....</b>	<b>46</b>
7.1.	Top and Bottom View of SIM800C.....	46
7.2.	Typical Solder Reflow Profile .....	46
7.3.	The Moisture Sensitivity Level.....	46
7.4.	Baking Requirements .....	47
<b>8.</b>	<b>Appendix.....</b>	<b>48</b>
I.	Related Documents .....	48
II.	Multiplexing Function.....	49

III.	Terms and Abbreviations .....	49
IV.	Safety Caution.....	51

SIMCOM CONFIDENTIAL FILE

## Table Index

TABLE 1: MODULE INFORMATION .....	9
TABLE 2: SIM800C KEY FEATURES .....	9
TABLE 3: CODING SCHEMES AND MAXIMUM NET DATA RATES OVER AIR INTERFACE .....	11
TABLE 4: OVERVIEW OF OPERATING MODES.....	11
TABLE 5: PIN DESCRIPTION .....	13
TABLE 6: RECOMMENDED ZENER DIODE .....	17
TABLE 7: THE CURRENT CONSUMPTION OF FUNCTION MODE.....	22
TABLE 8: SERIAL PORT AND USB PIN DEFINITION .....	24
TABLE 9: SERIAL PORT CHARACTERISTICS.....	25
TABLE 10: USB_VBUS OPERATION VOLTAGE .....	27
TABLE 11: RI BEHAVIORS.....	28
TABLE 12: AUDIO INTERFACE DEFINITION .....	29
TABLE 13: MICROPHONE INPUT CHARACTERISTICS.....	30
TABLE 14: AUDIO OUTPUT CHARACTERISTICS .....	31
TABLE 15: SIM PIN DEFINITION.....	31
TABLE 16: PIN DESCRIPTION (MOLEX SIM CARD HOLDER) .....	33
TABLE 17: PIN DESCRIPTION (AMPHENOL SIM CARD HOLDER).....	34
TABLE 18: PIN DEFINITION OF THE ADC.....	34
TABLE 19: ADC SPECIFICATION .....	35
TABLE 20: PIN DEFINITION OF THE NETLIGHT .....	35
TABLE 21: STATUS OF THE NETLIGHT PIN.....	35
TABLE 22: NETLIGHT MULTIPLEXING FUNCTION.....	35
TABLE 23: PIN DEFINITION OF THE STATUS.....	36
TABLE 24: STATUS MULTIPLEXING FUNCTION .....	36
TABLE 25: DEFINITION OF THE RF_SYNC PIN.....	36
TABLE 26: RF_SYNC MULTIPLEXING FUNCTION.....	36
TABLE 27: ABSOLUTE MAXIMUM RATINGS.....	41
TABLE 28: RECOMMENDED OPERATING CONDITIONS .....	41
TABLE 29: DIGITAL INTERFACE CHARACTERISTICS .....	41
TABLE 30: SIM CARD INTERFACE CHARACTERISTICS .....	41
TABLE 31: SIM_VDD CHARACTERISTICS.....	42
TABLE 32: VDD_EXT CHARACTERISTICS .....	42
TABLE 33: VRTC CHARACTERISTICS .....	42
TABLE 34: CURRENT CONSUMPTION .....	42
TABLE 35: THE ESD CHARACTERISTICS (TEMPERATURE: 25°C, HUMIDITY: 45 %).....	43
TABLE 36: GSM850 AND EGSM900 CONDUCTED RF OUTPUT POWER.....	44
TABLE 37: DCS1800 AND PCS1900 CONDUCTED RF OUTPUT POWER.....	44
TABLE 38: CONDUCTED RF RECEIVE SENSITIVITY .....	45
TABLE 39: OPERATING FREQUENCIES.....	45
TABLE 40: MOISTURE SENSITIVITY LEVEL AND FLOOR LIFE.....	47
TABLE 41: BAKING REQUIREMENTS .....	47
TABLE 42: RELATED DOCUMENTS .....	48
TABLE 43: MULTIPLEXING FUNCTION .....	49
TABLE 44: TERMS AND ABBREVIATIONS.....	49
TABLE 45: SAFETY CAUTION.....	51

## Figure Index

FIGURE 1: SIM800C FUNCTIONAL DIAGRAM.....	12
FIGURE 2: PIN OUT DIAGRAM (TOP VIEW).....	13
FIGURE 3: DIMENSIONS OF SIM800C (UNIT: MM).....	15
FIGURE 4: RECOMMENDED PCB FOOTPRINT OUTLINE (UNIT: MM).....	16
FIGURE 5: REFERENCE CIRCUIT OF THE VBAT INPUT.....	17
FIGURE 6: REFERENCE CIRCUIT OF THE LDO POWER SUPPLY.....	17
FIGURE 7: REFERENCE CIRCUIT OF THE DC-DC POWER SUPPLY.....	18
FIGURE 8: VBAT VOLTAGE DROP DURING TRANSMIT BURST.....	18
FIGURE 9: THE MINIMAL VBAT VOLTAGE REQUIREMENT AT VBAT DROP.....	18
FIGURE 10: POWERED ON/DOWN MODULE USING TRANSISTOR.....	19
FIGURE 11: POWERED ON/DOWN MODULE USING BUTTON.....	19
FIGURE 12: TIMING OF POWER ON MODULE.....	19
FIGURE 13: TIMING OF POWER OFF SIM800C BY PWRKEY.....	20
FIGURE 14: TIMING OF RESTART SIM800C.....	22
FIGURE 15: RTC SUPPLY FROM CAPACITOR.....	23
FIGURE 16: RTC SUPPLY FROM NON-CHARGEABLE BATTERY.....	24
FIGURE 17: RTC SUPPLY FROM RECHARGEABLE BATTERY.....	24
FIGURE 18: CONNECTION OF THE SERIAL INTERFACES.....	26
FIGURE 19: RESISTOR MATCHING CIRCUIT.....	26
FIGURE 20 : DIODE ISOLATION CIRCUIT.....	26
FIGURE 21: TX LEVEL MATCHING CIRCUIT.....	27
FIGURE 22: RX LEVEL MATCHING CIRCUIT.....	27
FIGURE 23: USB REFERENCE CIRCUIT.....	27
FIGURE 24: CONNECTION FOR SOFTWARE UPGRADING AND DEBUGGING.....	28
FIGURE 25: UART1_RI BEHAVIOUR OF VOICE CALLING AS A RECEIVER.....	29
FIGURE 26: UART1_RI BEHAVIOUR OF URC OR RECEIVE SMS.....	29
FIGURE 27: UART1_RI BEHAVIOUR AS A CALLER.....	29
FIGURE 28: SPEAKER REFERENCE CIRCUIT.....	30
FIGURE 29: MICROPHONE REFERENCE CIRCUIT.....	30
FIGURE 30: REFERENCE CIRCUIT OF THE 8-PIN SIM CARD HOLDER.....	32
FIGURE 31: REFERENCE CIRCUIT OF THE 6-PIN SIM CARD HOLDER.....	32
FIGURE 32: MOLEX 91228 SIM CARD HOLDER.....	33
FIGURE 33: AMPHENOL C707 10M006 512 SIM CARD HOLDER.....	34
FIGURE 34: REFERENCE CIRCUIT OF NETLIGHT.....	35
FIGURE 35: RF_SYNC SIGNAL DURING TRANSMIT BURST.....	36
FIGURE 36: GSM ANTENNA MATCHING CIRCUIT.....	37
FIGURE 37: GSM ANTENNA MATCHING CIRCUIT WITHOUT RF CONNECTOR.....	37
FIGURE 38: BLUETOOTH ANTENNA MATCHING CIRCUIT.....	38
FIGURE 39: PIN ASSIGNMENT.....	39
FIGURE 40: TOP AND BOTTOM VIEW OF SIM800C.....	46
FIGURE 41: TYPICAL SOLDER REFLOW PROFILE OF LEAD-FREE PROCESSES.....	46

## Version History

Date	Version	Description of change	Author
2014-11-06	1.00	Origin	Yanwu.wang; Xiaobo.bai
2015-01-06	1.01	Update figure1,figure12,figure40 Delete figure26 Add VRTC segment to table5 Update table11,table34,table35,table36	Yanwu.wang; Xiaobo.bai
2015-04-27	1.02	Update figure7,figure10,figure11,figure10,figure12,figure13, figure14,figure23,figure37,figure38 Update table1,table2	Yanwu.wang; Xiaobo.bai
2015-10-20	1.03	<ol style="list-style-type: none"> <li>1. Update table 2 power saving.</li> <li>2. Update table 5 PWRKEY pulled up to 3V</li> <li>3. Update table 7 of AT+CFUN=1</li> <li>4. Update table 34 of current consumption</li> <li>5. Update figure30 and figure31</li> </ol>	Yanwu.wang; Xiaobo.bai

SIMCOM CONFIDENTIAL



## 1. Introduction

This document describes SIM800C hardware interface in great detail. The document can help customer to quickly understand SIM800C interface specifications, electrical and mechanical details. With the help of this document and other SIM800C application notes, customer guide, customers can use SIM800C to design various applications quickly.

## 2. SIM800C Overview

SIM800C is a quad-band GSM/GPRS module that works on frequencies GSM850MHz, EGSM900MHz, DCS1800MHz and PCS1900MHz. SIM800C features GPRS multi-slot class10/class12 (optional) and supports the GPRS coding schemes CS-1, CS-2, CS-3 and CS-4.

With a tiny configuration of 17.6\*15.7\*2.3mm, SIM800C can meet almost all the space requirements in customers' applications, such as smart phone, PDA and other mobile devices.

SIM800C is a SMT package with 42 pads, and provides all hardware interfaces between the module and customers' boards.

- One 3 lines serial port and one full modem serial port;
- One USB, the USB interface can debug, download software;
- One audio channel which include a microphone input and a speaker output;
- Programmable general purpose input and output;
- One SIM card interface;
- Support Bluetooth (need software support).

SIM800C is designed with power saving technique so that the current consumption is as low as 0.6mA in sleep mode.

### 2.1. SIM800C

**Table 1: Module information**

	<b>SIM800C</b>
GSM	850,900,1800 and 1900MHz
BT	(need software support)
FLASH	SIM800C (24Mbit) SIM800C32 (32Mbit)
RAM	32Mbit

### 2.2. SIM800C Key Features

**Table 2: SIM800C key features**

<b>Feature</b>	<b>Implementation</b>
Power supply	3.4V ~4.4V
Power saving	Typical power consumption in sleep mode is 0.6mA (AT+CFUN=0 )
Frequency bands	● Quad-band: GSM 850, EGSM 900, DCS 1800, PCS 1900. SIM800C can

	<p>search the 4 frequency bands automatically. The frequency bands can also be set by AT command “AT+CBAND”. For details, please refer to <i>document [1]</i>.</p> <ul style="list-style-type: none"> <li>● Compliant to GSM Phase 2/2+</li> </ul>
Transmitting power	<ul style="list-style-type: none"> <li>● Class 4 (2W) at GSM 850 and EGSM 900</li> <li>● Class 1 (1W) at DCS 1800 and PCS 1900</li> </ul>
GPRS connectivity	<ul style="list-style-type: none"> <li>● GPRS multi-slot class 12 ( default )</li> <li>● GPRS multi-slot class 1~12 (option)</li> </ul>
Temperature range	<ul style="list-style-type: none"> <li>● Normal operation: -40°C ~ +85°C</li> <li>● Storage temperature -45°C ~ +90°C</li> </ul>
Data GPRS	<ul style="list-style-type: none"> <li>● GPRS data downlink transfer: max. 85.6 kbps</li> <li>● GPRS data uplink transfer: max. 85.6 kbps</li> <li>● Coding scheme: CS-1, CS-2, CS-3 and CS-4</li> <li>● PAP protocol for PPP connect</li> <li>● Integrate the TCP/IP protocol.</li> <li>● Support Packet Broadcast Control Channel (PBCCH)</li> </ul>
USSD	<ul style="list-style-type: none"> <li>● Unstructured Supplementary Services Data (USSD) support</li> </ul>
SMS	<ul style="list-style-type: none"> <li>● MT, MO, CB, Text and PDU mode</li> <li>● SMS storage: SIM card</li> </ul>
SIM interface	Support SIM card: 1.8V, 3V
External antenna	Antenna pad
Audio features	<p>Speech codec modes:</p> <ul style="list-style-type: none"> <li>● Half Rate (ETS 06.20)</li> <li>● Full Rate (ETS 06.10)</li> <li>● Enhanced Full Rate (ETS 06.50 / 06.60 / 06.80)</li> <li>● Adaptive multi rate (AMR)</li> <li>● Echo Cancellation</li> <li>● Noise Suppression</li> </ul>
Serial port and USB port	<p><b>Serial port:</b></p> <ul style="list-style-type: none"> <li>● Default one Full modem serial port</li> <li>● Can be used for AT commands or data stream</li> <li>● Support RTS/CTS hardware handshake and software ON/OFF flow control</li> <li>● Multiplex ability according to GSM 07.10 Multiplexer Protocol</li> <li>● Autobauding supports baud rate from 1200 bps to 115200bps</li> <li>● upgrading firmware</li> </ul> <p><b>USB port:</b></p> <ul style="list-style-type: none"> <li>● USB_DN and USB_DP</li> <li>● Can be used for debugging and upgrading firmware</li> </ul>
Phonebook management	Support phonebook types: SM, FD, LD, RC, ON, MC
SIM application toolkit	GSM 11.14 Release 99
Physical characteristics	<p>Size:17.6*15.7*2.3mm</p> <p>Weight:1.3g</p>
Firmware upgrade	Full modern serial port or USB port(recommend to use USB port)

**Table 3: Coding schemes and maximum net data rates over air interface**

Coding scheme	1 timeslot	2 timeslot	4 timeslot
CS-1	9.05kbps	18.1kbps	36.2kbps
CS-2	13.4kbps	26.8kbps	53.6kbps
CS-3	15.6kbps	31.2kbps	62.4kbps
CS-4	21.4kbps	42.8kbps	85.6kbps

### 2.3. Operating Mode

The table below summarizes the various operating modes of SIM800C.

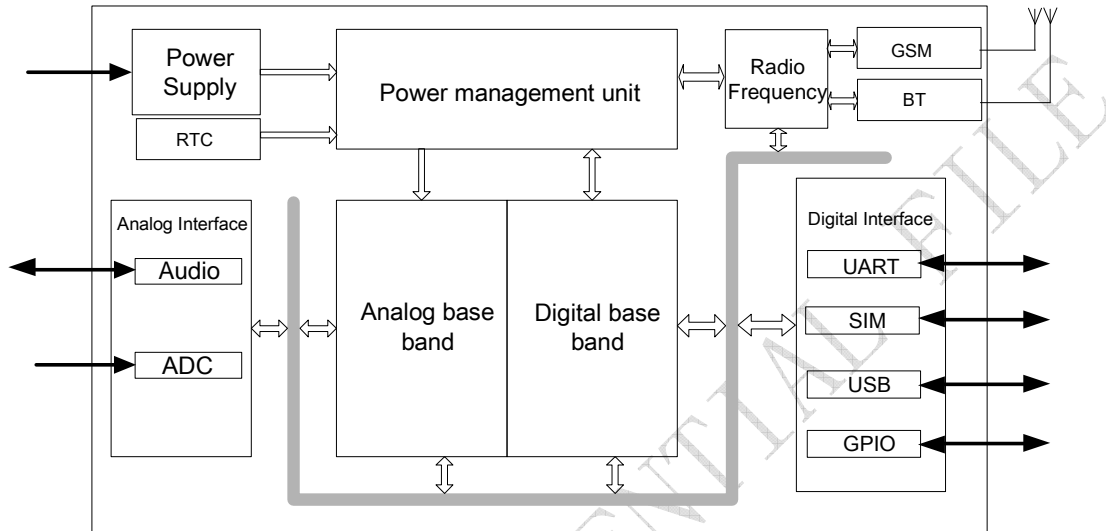
**Table 4: Overview of operating modes**

Mode	Function
Normal operation	GSM/GPRS SLEEP Module will automatically go into sleep mode if the conditions of sleep mode are enabling and there aren't on air and hardware interrupt (such as GPIO interrupt or data on serial port). In this case, the current consumption of module will reduce to the minimal level. In sleep mode, the module can still receive paging message and SMS.
	GSM IDLE Software is active. Module is registered to the GSM network, and the module is ready to communicate.
	GSM TALK Connection between two subscribers is in progress. In this case, the power consumption depends on network settings such as DTX off/on, FR/EFR/HR, hopping sequences, antenna.
	GPRS STANDBY Module is ready for GPRS data transfer, but no data is currently sent or received. In this case, power consumption depends on network settings and GPRS configuration.
	GPRS DATA There is GPRS data transfer (PPP or TCP or UDP) in progress. In this case, power consumption is related with network settings (e.g. power control level); uplink/downlink data rates and GPRS configuration (e.g. used multi-slot settings).
Power off	Normal power off by sending AT command "AT+CPOWD=1" or using the PWRKEY. The power management unit shuts down the power supply for the baseband part of the module. Software is not active. The serial port is not accessible. Power supply (connected to VBAT) remains applied.
Minimum functionality mode	AT command "AT+CFUN" can be used to set the module to a minimum functionality mode without removing the power supply. In this mode, the RF part of the module will not work or the SIM card will not be accessible, or both RF part and SIM card will be closed, and the serial port is still accessible. The power consumption in this mode is lower than normal mode.

## 2.4. Functional Diagram

The following figure shows a functional diagram of SIM800C:

- GSM baseband
- GSM RF
- Antenna interface
- Other interface



**Figure 1: SIM800C functional diagram**

### 3. Package Information

#### 3.1. Pin Out Diagram

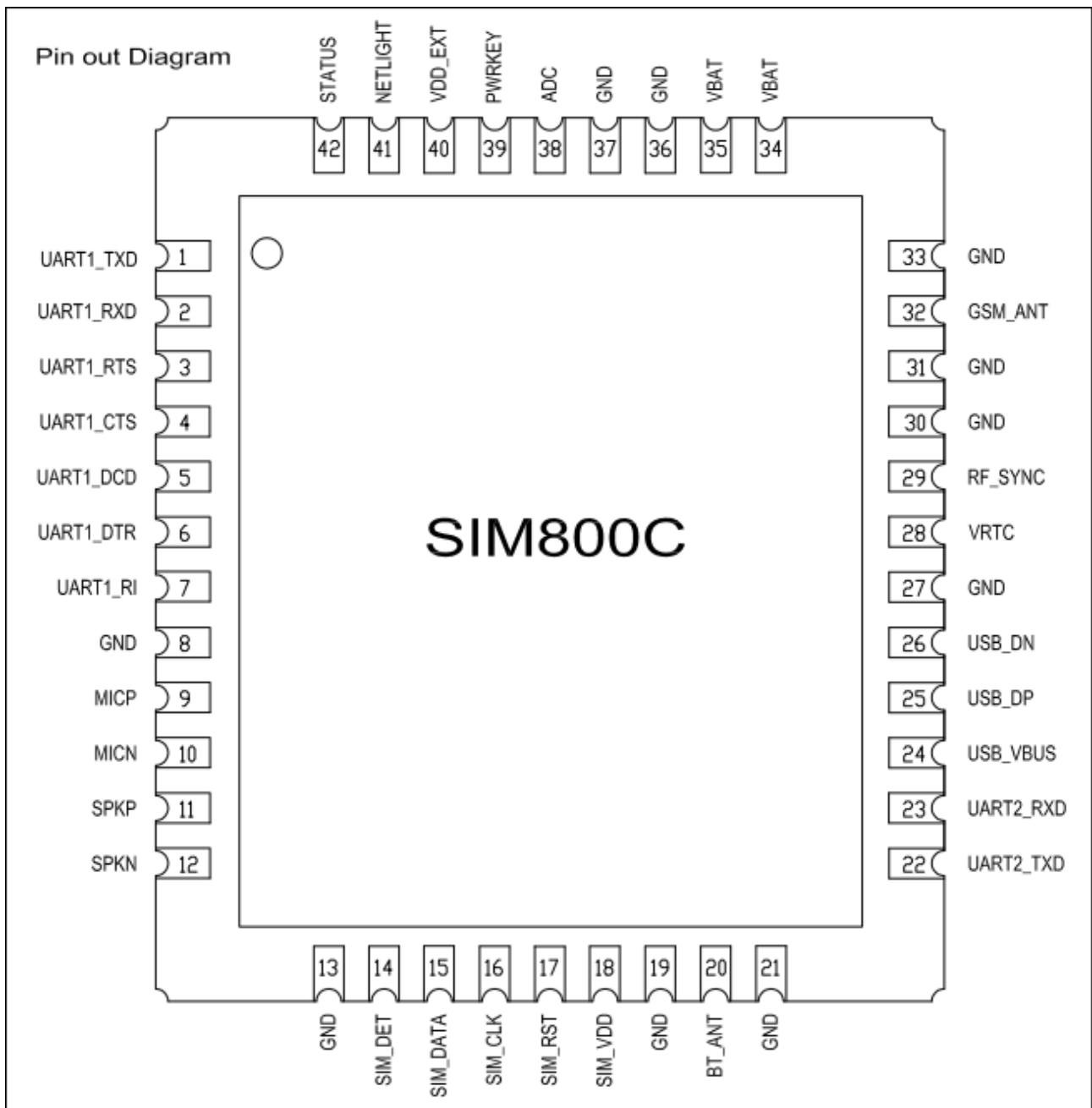


Figure 2: Pin out Diagram (Top view)

#### 3.2. Pin Description

Table 5: Pin description

Pin name	Pin number	I/O	Description	Comment
<b>Power supply</b>				
VBAT	34,35	I	Power supply	

VRTC	28	I/O	Power supply for RTC	It is recommended to connect with a battery or a capacitor (e.g. 4.7uF).
VDD_EXT	40	O	2.8V power output	If these pins are unused, keep open.
GND	8,13,19,21,27,30, 31,33,36,37		Ground	GND for VBAT recommend to use 36,37pin
<b>Power on/down</b>				
PWRKEY	39	I	PWRKEY should be pulled low at least 1 second and then released to power on/down the module.	Internally pulled up to 3V.
<b>Audio interfaces</b>				
MICP	9	I	Differential audio input	If these pins are unused, keep open.
MICN	10			
SPKP	11	O	Differential audio output	
SPKN	12			
<b>GPIO</b>				
NETLIGHT	41	O	Network status	
STATUS	42	O	Power on status	
<b>Serial port</b>				
UART1_DTR	6	I	Data terminal ready	If these pins are unused, keep open.
UART1_RI	7	O	Ring indicator	
UART1_DCD	5	O	Data carrier detect	
UART1_CTS	4	O	Clear to send	
UART1_RTS	3	I	Request to send	
UART1_TXD	1	O	Transmit data	
UART1_RXD	2	I	Receive data	
UART2_TXD	22	O	Transmit data	
UART2_RXD	23	I	Receive data	
<b>Debug interface</b>				
USB_VBUS	24	I	Debug and download	If these pins are unused, keep open.
USB_DP	25	I/O		
USB_DN	26	I/O		
<b>ADC</b>				
ADC	38	I	10bit general analog to digital converter	If these pins are unused, keep open.
<b>SIM card interface</b>				
SIM_VDD	18	O	Voltage supply for SIM card. Support 1.8V or 3V SIM card	All signals of SIM interface should be protected against ESD with a TVS diode array.
SIM_DATA	15	I/O	SIM data input/output	
SIM_CLK	16	O	SIM clock	
SIM_RST	17	O	SIM reset	
SIM_DET	14	I	SIM card detection	If these pins are unused,

				keep open.
<b>Antenna interface</b>				
GSM_ANT	32	I/O	Connect GSM antenna	
BT_ANT	20	I/O	Connect Bluetooth antenna	
<b>Synchronizing signal of RF</b>				
RF_SYNC	29	O	Synchronizing signal of RF	

### 3.3. Package Dimensions

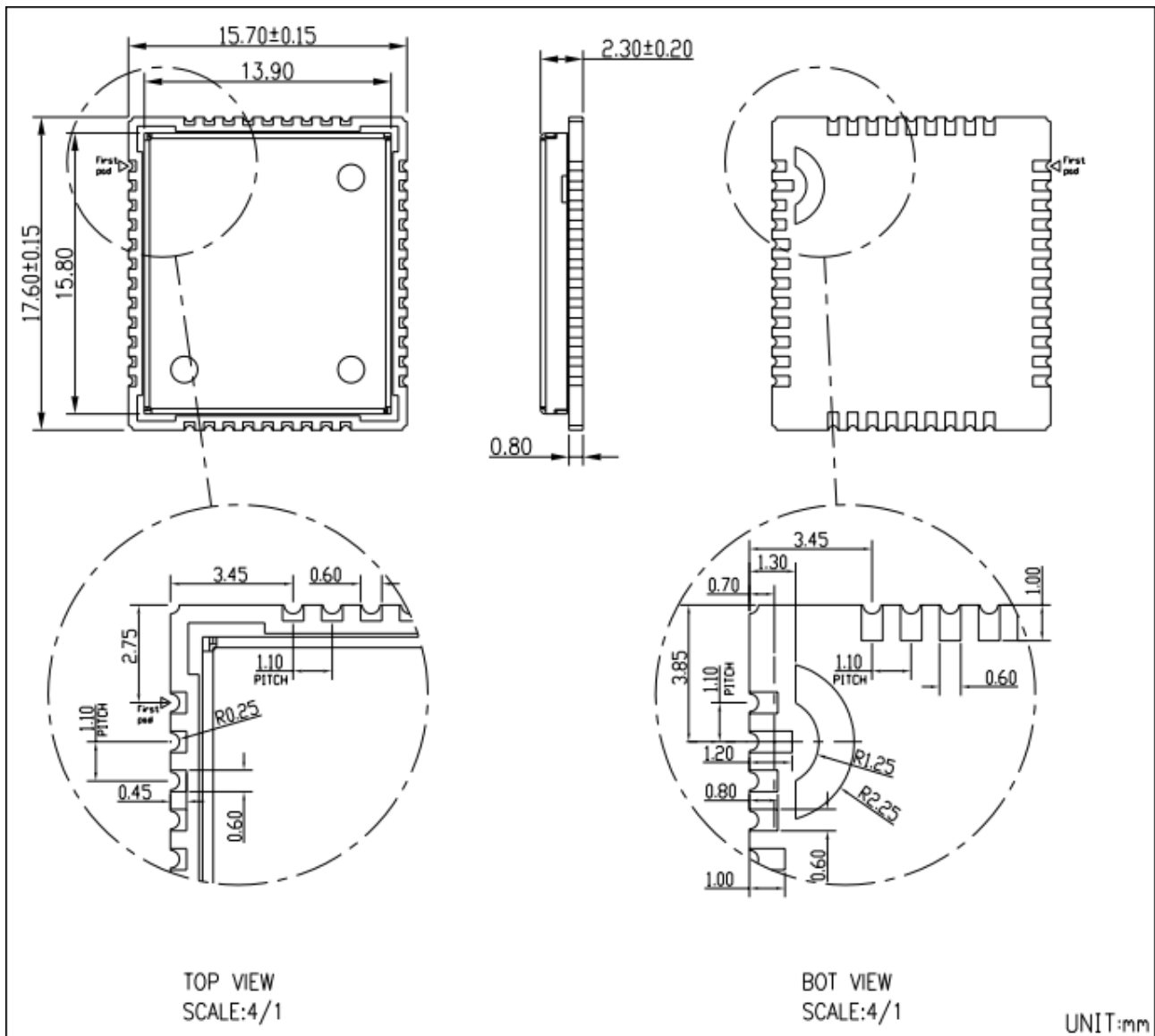


Figure 3: Dimensions of SIM800C (Unit: mm)

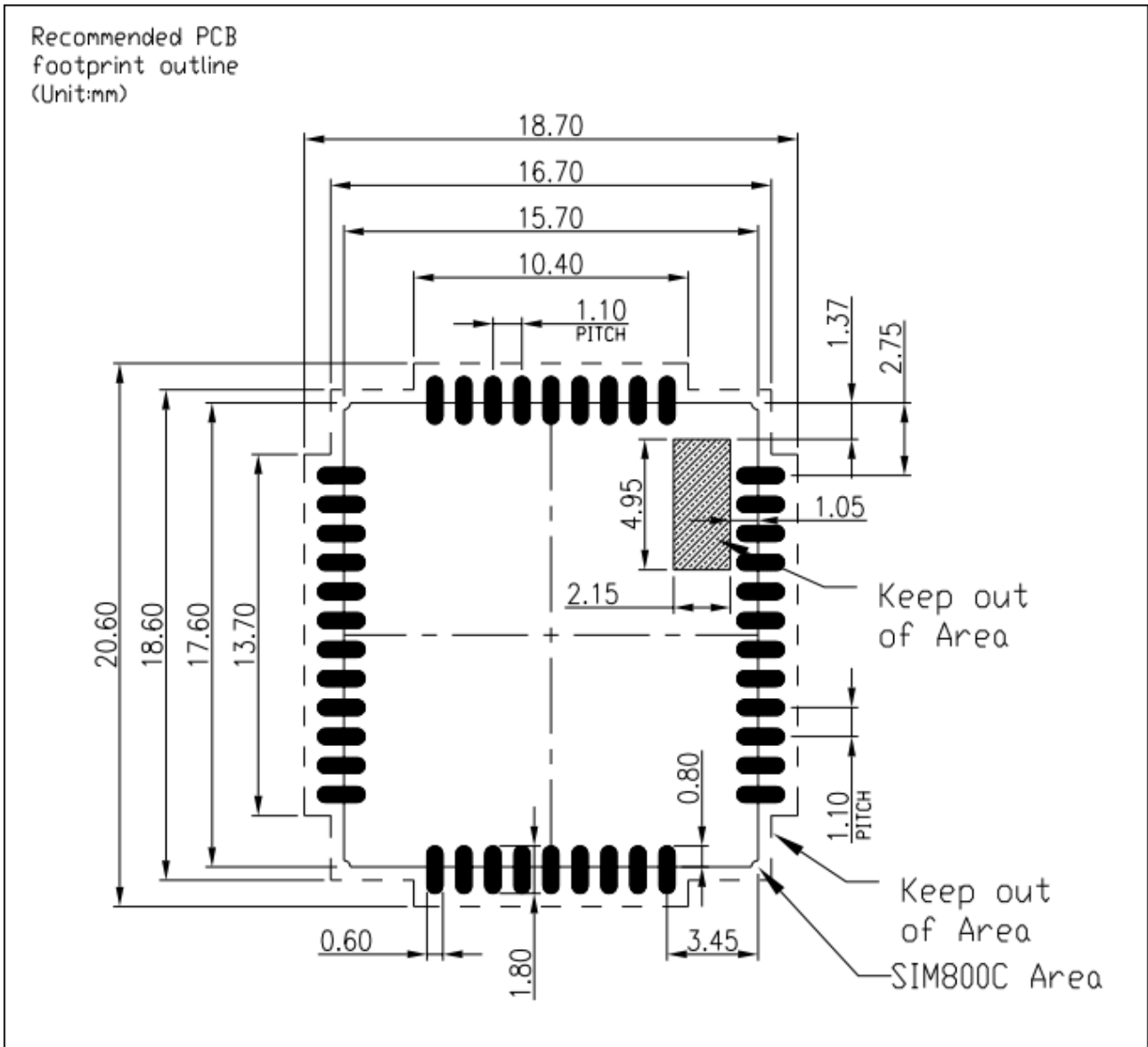


Figure 4: Recommended PCB footprint outline (Unit: mm)



## 4. Application Interface

### 4.1. Power Supply

The power supply range of SIM800C is from 3.4V to 4.4V. Recommended voltage is 4.0V. The transmitting burst will cause voltage drop and the power supply must be able to provide sufficient current up to 2A. For the VBAT input, a bypass capacitor (low ESR) such as a 100  $\mu$ F is strongly recommended.

For the VBAT input, a 100uF Tantalum capacitor ( $C_A$  low ESR) and a 1uF~10uF Ceramics capacitor  $C_B$  are strongly recommended. Increase the 33pF and 10pF capacitors can effectively eliminate the high frequency interference. A 5.1V/500mW Zener diode is strongly recommended, the diode can prevent chip from damaging by the voltage surge. These capacitors and Zener diode should be placed as close as possible to SIM800C VBAT pins.

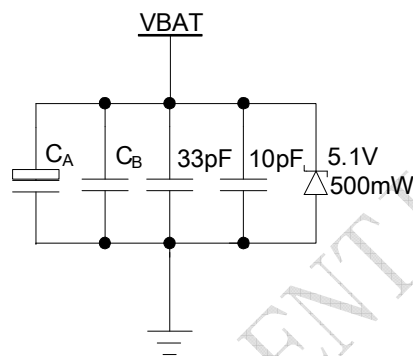


Figure 5: Reference circuit of the VBAT input

Table 6: Recommended zener diode

	Vendor	Part number	Power(watts)	Packages
1	On semi	MMSZ5231BT1G	500mW	SOD123
2	Prisemi	PZ3D4V2H	500mW	SOD323
3	Vishay	MMSZ4689-V	500mW	SOD123
4	Crownpo	CDZ55C5V1SM	500mW	0805

The following figure is the reference design of +5V input power supply. The output power supply is 4.1V, thus a linear regulator can be used.

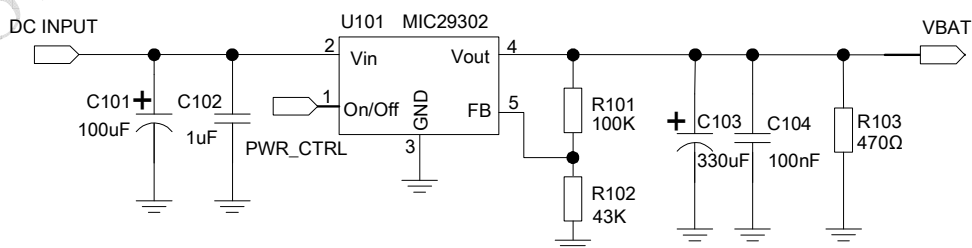
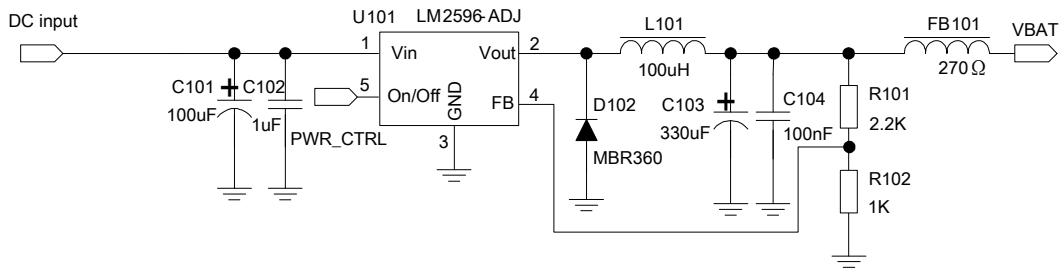


Figure 6: Reference circuit of the LDO power supply

If there is a high drop-out between the input and the desired output (VBAT), a DC-DC power supply will be preferable because of its better efficiency especially with the 2A peak current in burst mode of the module. The

following figure is the reference circuit.



**Figure 7: Reference circuit of the DC-DC power supply**

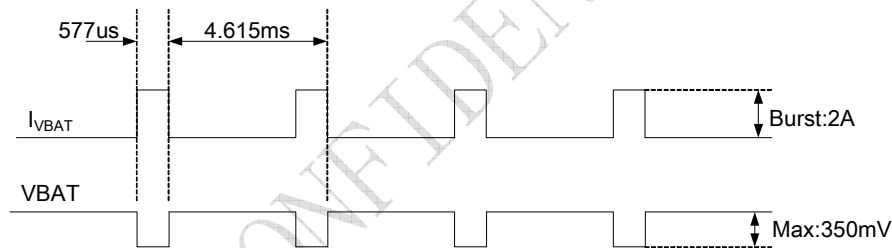
The single 3.7V Li-ion cell battery can be connected to SIM800C VBAT pins directly. But the Ni-Cd or Ni-MH battery must be used carefully, since their maximum voltage can rise over the absolute maximum voltage of the module and damage it.

When battery is used, the total impedance between battery and VBAT pins should be less than 150mΩ. The following figure shows the VBAT voltage drop at the maximum power transmit phase, and the test condition is as following:

VBAT=4.0V,

A VBAT bypass capacitor  $C_A=100\mu\text{F}$  tantalum capacitor (ESR=0.7Ω),

Another VBAT bypass capacitor  $C_B=1\mu\text{F}\sim 10\mu\text{F}$ .

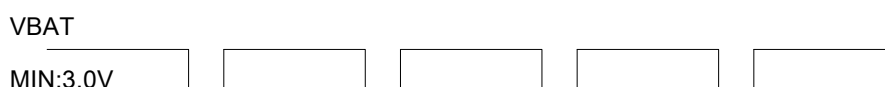


**Figure 8: VBAT voltage drop during transmit burst**

#### 4.1.1. Power Supply Pin

Pin34 and Pin35 are VBAT input, Pin36 and Pin37 are GND of power supply, and VRTC pin is power supply of the RTC circuit in the module. VDD\_EXT output 2.8V when module is in normal operation mode.

When designing the power supply in customers' application, pay special attention to power losses. Ensure that the input voltage never drops below 3.0V even when current consumption rises to 2A in the transmit burst. If the power voltage drops below 3.0V, the module may be shut down automatically. The PCB traces from the VBAT pins to the power supply must be wide enough (at least 60mil) to decrease voltage drops in the transmit burst. The power IC and the bypass capacitor should be placed to the module as close as possible.



**Figure 9: The minimal VBAT voltage requirement at VBAT drop**

*Note: Hardware power off voltage is 3.0V.*

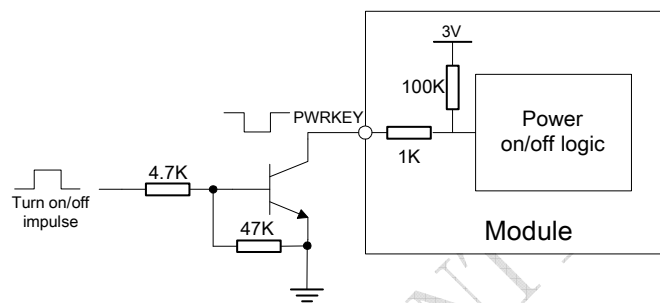
### 4.1.2. Monitoring Power Supply

AT command “AT+CBC” can be used to monitor the VBAT voltage. For detail, please refer to *document [1]*.

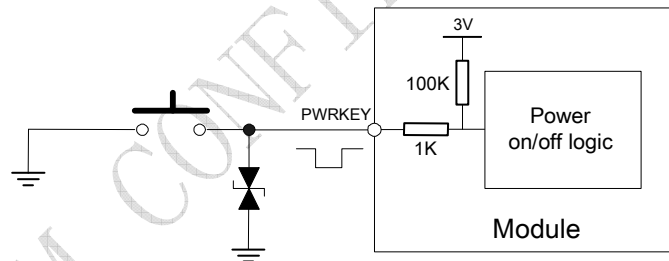
## 4.2. Power on/off SIM800C

### 4.2.1. Power on SIM800C

Customer can power on SIM800C by pulling down the PWRKEY pin for at least 1 second and release. This pin is already pulled up to 3V in the module internal, so external pull up is not necessary. Reference circuits are shown as below.

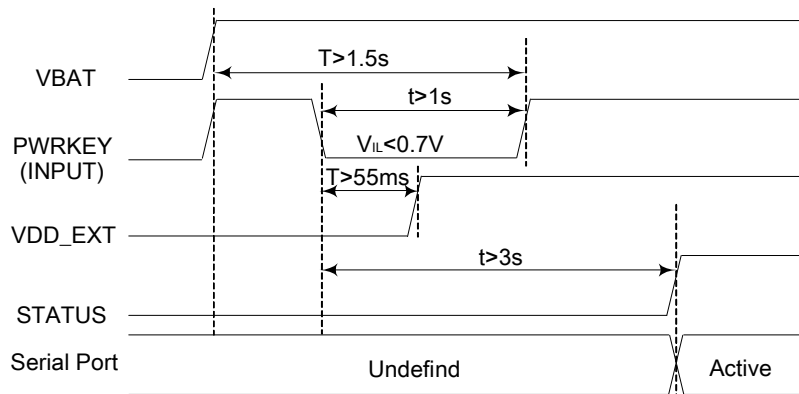


**Figure 10: Powered on/down module using transistor**



**Figure 11: Powered on/down module using button**

The power on timing is illustrated as in the following figure.



**Figure 12: Timing of power on module**

When power on procedure is completed, SIM800C will send following URC to indicate that the module is ready to operate at fixed baud rate.

### **RDY**

This URC does not appear when autobauding function is active.

*Note: Customer can use AT command “AT+IPR=x” to set a fixed baud rate and save the configuration to non-volatile flash memory. After the configuration is saved as fixed baud rate, the Code “RDY” should be received from the serial port every time when SIM800C is powered on. For details, please refer to the chapter “AT+IPR” in document [1].*

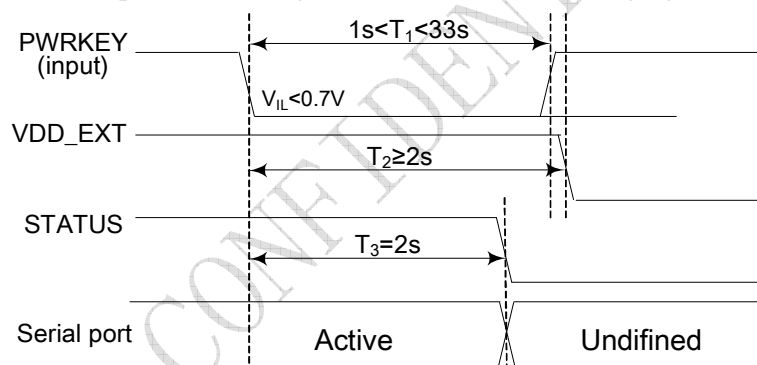
## **4.2.2. Power off SIM800C**

SIM800C will be powered off in the following situations:

- Normal power off procedure: power off SIM800C by the PWRKEY pin.
- Normal power off procedure: power off SIM800C by AT command “AT+CPOWD=1”.
- Abnormal power off: over-voltage or under-voltage automatic power off.
- Abnormal power off: over-temperature or under-temperature automatic power off.

### **4.2.2.1. Power off SIM800C by the PWRKEY Pin**

Customer can power off SIM800C by pulling down the PWRKEY pin for at least 1 second and release. Please refer to the power on circuit. The power off timing is illustrated in the following figure.



**Figure 13: Timing of power off SIM800C by PWRKEY**

#### **Note:**

1. the module will restart after pull down the pwrkey over 33 seconds.
2. VDD\_EXT will power off after STATUS change into low level and the PWRKEY release 55ms..  
 If  $1s < T_1 < 2s$ ,  $T_2 > 2s$ ;  
 If  $2s \leq T_1 < 33s$ ,  $T_2 > T_1 + 55ms$

This procedure makes the module log off from the network and allows the software to enter into a secure state to save data before completely shut down.

Before the completion of the power off procedure, the module will send URC:

### **NORMAL POWER OFF**

At this moment, AT commands can not be executed any more. Power off mode can also be indicated by STATUS pin, which is at low level at this time.

### **4.2.2.2. Power off SIM800C by AT Command**

SIM800C can be powered off by AT command “AT+CPOWD=1”. This procedure makes the module log off from the network and allows the software to enter into a secure state to save data before completely shut down.

Before the completion of the power off procedure, the module will send URC:

***NORMAL POWER OFF***

At this moment, AT commands can not be executed any more. Power off mode can also be indicated by STATUS pin, which is at low level at this time.

For detail about AT command “AT+CPOWD”, please refer to *document [1]*.

**4.2.2.3. Over-Voltage or Under-Voltage Power off**

The module software monitors the VBAT voltage constantly.

If the voltage  $\leq 3.5V$ , the following URC will be reported:

***UNDER-VOLTAGE WARNNING***

If the voltage  $\geq 4.3V$ , the following URC will be reported:

***OVER-VOLTAGE WARNNING***

If the voltage  $< 3.4V$ , the following URC will be reported, and the module will be automatically powered off.

***UNDER-VOLTAGE POWER OFF***

If the voltage  $> 4.4V$ , the following URC will be reported, and the module will be automatically powered off.

***OVER-VOLTAGE POWER OFF***

At this moment, AT commands can not be executed any more. Power off mode can also be indicated by STATUS pin, which is at low level at this time.

**4.2.2.4. Over-Temperature or Under-Temperature Power off**

The module will constantly monitor the temperature of the module,

If the temperature  $\geq +80^{\circ}C$ , the following URC will be reported:

***+CMTE: 1***

If the temperature  $\leq -30^{\circ}C$ , the following URC will be reported:

***+CMTE:-1***

If the temperature  $> +85^{\circ}C$ , the following URC will be reported, and the module will be automatically powered off.

***+CMTE: 2***

If the temperature  $< -40^{\circ}C$ , the following URC will be reported, and the module will be automatically powered off.

***+CMTE:-2***

At this moment, AT commands can not be executed any more. Power off mode can also be indicated by STATUS pin, which is at low level at this time.

**Note:** *The default temperature detect is disable, AT command “AT+CMTE” could be used to read the temperature when the module is running. For details please refer to document [1].*

**4.2.2.5. Restart SIM800C by PWRKEY Pin:**

When the module works normally, if the customer wants to restart the module, follow the procedure below:

- 1) Power off the module.
- 2) Wait for at least 800ms after STATUS pin changed to low level.

3) Power on the module.

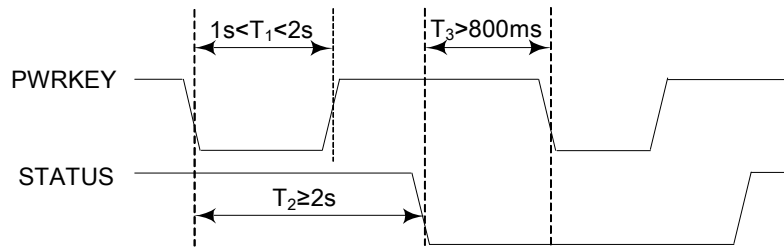


Figure 14: Timing of restart SIM800C

### 4.3. Power Saving Mode

SIM800C has two power saving modes: Minimum functionality mode and sleep mode. AT command “AT+CSCLK=1” can be used to set SIM800C into sleep mode. AT command “AT+CFUN=<fun>” can be used to set SIM800C into minimum functionality. When SIM800C is in sleep mode and minimum functionality mode, the current of module is lowest.

#### 4.3.1. Minimum Functionality Mode

There are three functionality modes, which could be set by AT command “AT+CFUN=<fun>”. The command provides the choice of the functionality levels <fun>=0, 1, 4.

- AT+CFUN=0: Minimum functionality.
- AT+CFUN=1: Full functionality (default).
- AT+CFUN=4: Flight mode (disable RF function).

Table 7: The current consumption of Function Mode

<fun>	BS-PA-MFRMS	Current consumption(mA)
0	/	0.6
1	9	0.9
	5	1
	2	1.5
4	/	0.64

Minimum functionality mode minimizes the current consumption to the lowest level. If SIM800C is set to minimum functionality by “AT+CFUN=0”, the RF function and SIM card function will be disabled. In this case, the serial port is still accessible, but partial AT commands and correlative to RF function and SIM card function will not be accessible.

For detailed information about AT command “AT+CFUN=<fun>”, please refer to *document [1]*.

#### 4.3.2. Sleep Mode 1 (AT+CSCLK=1)

Customer can control SIM800C module to enter or exit the sleep mode (AT+CSCLK=1) by DTR signal. When DTR is in high level and without interrupt (on air and hardware such as GPIO interrupt or data in serial port), SIM800C will enter sleep mode automatically. In this mode, SIM800C can still receive paging or SMS from network but the serial port is not accessible.

### 4.3.3. Wake Up SIM800C from Sleep Mode 1

When SIM800C is in sleep mode 1(AT+CSCLK=1), the following methods can wake up the module:

- Pull down DTR pin.  
The serial port will be active after DTR pin is pulled to low level for about 50ms.
- Receive a voice or data call from network.
- Receive a SMS from network.
- Receive external interrupt.

*Note: After module has received incoming call or new SMS, serial port can report URC, but the serial port can not input AT command. Only after the DTR pin is pulled to low level for 50ms, the serial port can input AT command.*

### 4.3.4. Sleep Mode 2 (AT+CSCLK=2)

In this mode, SIM800C will continuously monitor the serial port data signal. When there is no data transfer over 5 seconds on the RXD signal and there is no on air and hardware interrupts (such as GPIO interrupt), SIM800C will enter sleep mode 2 automatically. In this mode, SIM800C can still receive paging or SMS from network.

### 4.3.5. Wake Up SIM800C from Sleep Mode 2

When SIM800C is in sleep mode 2 (AT+CSCLK=2), the following methods can wake up the module:

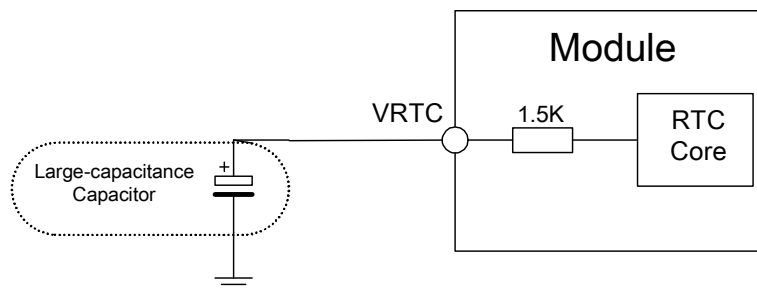
- Send data to SIM800C via main serial port (the first character will lose).
- Receive a voice or data call from network.
- Receive a SMS from network.

*Note: Autobauding is default. It cannot enter sleep mode in the absence of synchronous serial port baud rate after module power on.*

## 4.4. Power Saving Mode

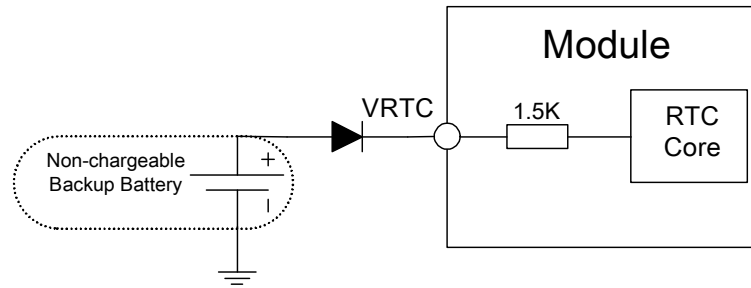
Current input for RTC when the VBAT is not supplied for the system. Current output for backup battery when the VBAT power supply is in present and the backup battery is in low voltage state. The RTC power supply of module can be provided by an external capacitor or a battery (non-chargeable or rechargeable) through the VRTC. The following figures show various reference circuits for RTC back up.

- **External capacitor backup**



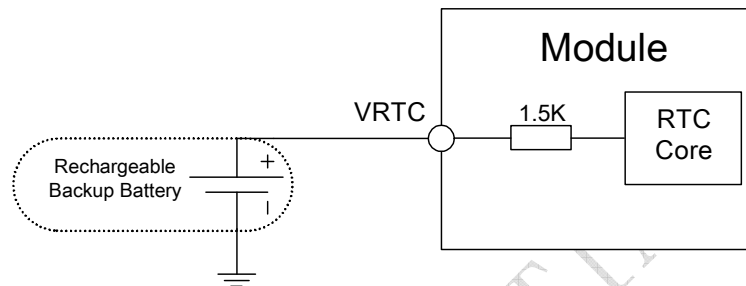
**Figure 15: RTC supply from capacitor**

- **Non-chargeable battery backup**



**Figure 16: RTC supply from non-chargeable battery**

- **Rechargeable battery backup**



**Figure 17: RTC supply from rechargeable battery**

*Note: When shut off VBAT and power on VRTC only, the clock error becomes larger.*

#### 4.5. Serial Port and USB Interface

SIM800C default provides one unbalanced asynchronous serial ports. The module is designed as a DCE (Data Communication Equipment). The following figure shows the connection between module and client (DTE).

**Table 8: Serial port and USB pin definition**

	Pin name	Pin number	Function
Serial port	UART1_DTR	6	Data terminal ready
	UART1_RI	7	Ring indicator
	UART1_DCD	5	Data carrier detect
	UART1_CTS	4	Clear to send
	UART1_RTS	3	Request to send
	UART1_TXD	1	Transmit data
	UART1_RXD	2	Receive data
	UART2_TXD	22	Transmit data
UART2_RXD	23	Receive data	
Debug port	USB_VBUS	24	USB power supply
	USB_DP	25	D+ data input/output
	USB_DN	26	D- data input/output



*Note: Hardware flow control is disabled by default. AT command “AT+IFC=2, 2” can enable hardware flow control. AT command “AT+IFC=0,0” can disable hardware flow control. For more details please refer to document [1].*

**Table 9: Serial port characteristics**

Symbol	Min	Max	Unit
V <sub>IL</sub>	-0.3	0.7	V
V <sub>IH</sub>	2.1	3.1	V
V <sub>OL</sub>	-	0.4	V
V <sub>OH</sub>	2.4	-	V

#### 4.5.1 Function of Serial Port

Serial port:

- Full mode device.
- Contain data lines UART1\_TXD/UART1\_RXD, hardware flow control lines UART1\_RTS/UART1\_CTS, status lines UART1\_DTR、UART1\_DCD and UART1\_RI.
- Serial port can be used for GPRS service and AT communication. It can also be used for multiplexing function. For details about multiplexing function, please refer to *table 11*.
- Autobauding supports the following baud rates:  
1200, 2400, 4800, 9600, 19200, 38400, 57600 and 115200bps

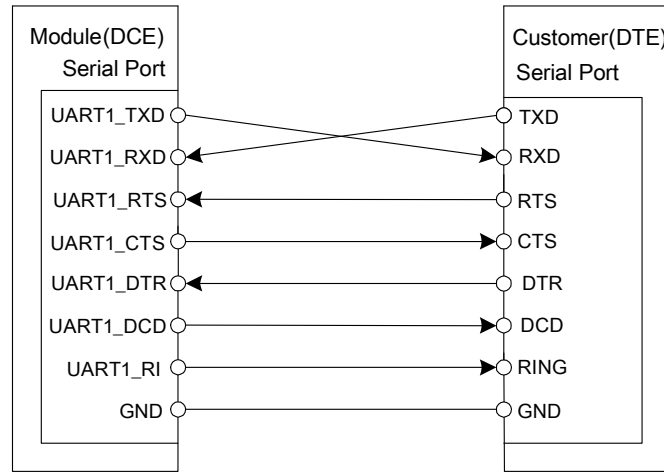
Autobauding allows SIM800C to automatically detect the baud rate of the host device. Pay more attention to the following requirements:

- **Synchronization between DTE and DCE:**  
When DCE powers on with autobauding enabled, it is recommended to send "AT" or "at" or "aT" or "At" to synchronize the baud rate, until DTE receives the "OK" response, which means DTE and DCE are correctly synchronized. For more information please refer to AT command "AT+IPR".
- **Restrictions of autobauding operation:**  
The DTE serial port must be set at 8 data bits, no parity and 1 stop bit.  
The URC such as "RDY", "+CFUN: 1" and "+CPIN: READY" will not be reported.

*Note: Customer can use AT command “AT+IPR=x” to set a fixed baud rate and the setting will be saved to non-volatile flash memory automatically. After the configuration is set as fixed baud rate, the URC such as "RDY", "+CFUN: 1" and "+CPIN: READY" will be reported when SIM800C is powered on.*

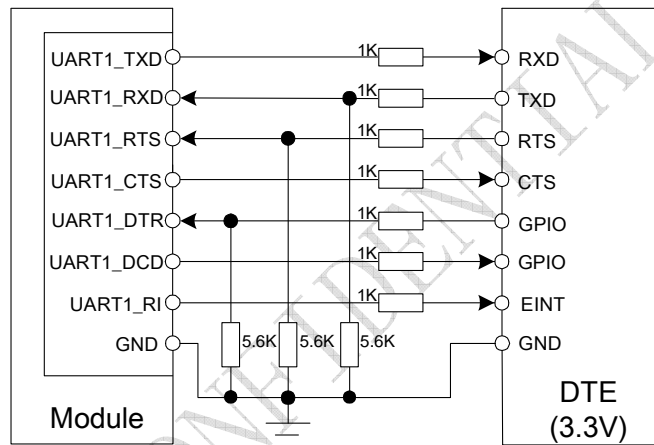
#### 4.5.2 Serial Interfaces

The following figure shows the connection between module and client (DTE).



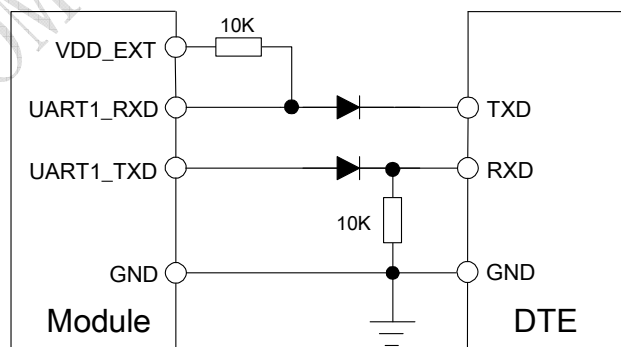
**Figure 18: Connection of the serial interfaces**

If the voltage of UART is 3.3V, the following reference circuits are recommended. If the voltage is 3.0V, please change the resistors in the following figure from 5.6K to 14K.



**Figure 19: Resistor matching circuit**

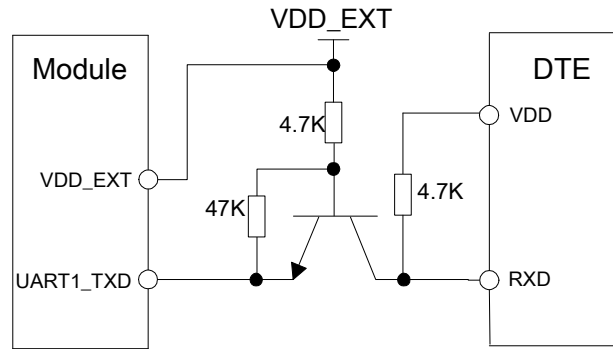
If the voltage of UART is 3V or 3.3V, the following reference circuits are recommended:



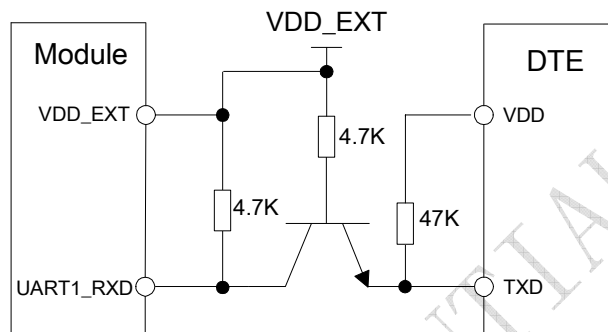
**Figure 20 : Diode isolation circuit**

*Note: please make sure the minimum of client high limit should be less than 2.8V minus the diode drop.*

If the voltage of UART is 5V, the following reference circuits are recommended:



**Figure 21: TX level matching circuit**

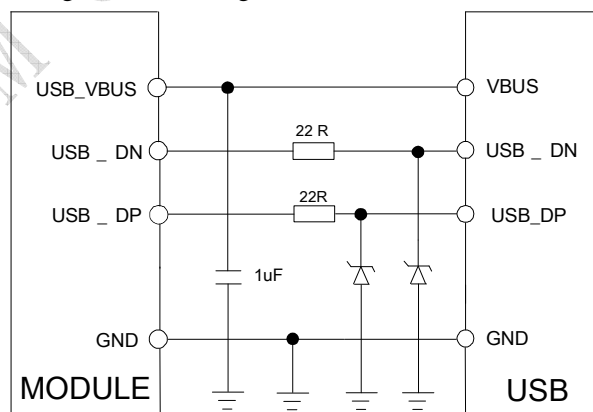


**Figure 22: RX level matching circuit**

### 4.5.3 Debug Interface

SIM800C could achieve software debug function through USB interface. When powering on the module, connect USB\_VBUS, USB\_DP, USB\_DN, and GND to PC, then install the driver following the prompts, a UART port could be recognized by PC, customer could achieve the software Debug with this UART port.

SIMCom recommended the following connected diagram:



**Figure 23: USB reference circuit**

The TVS on USB data line should be less than 5pF, and traced by differential forms.

*Note: please reserve the USB interface or test point for the further debugging*

**Table 10: USB\_VBUS operation voltage**

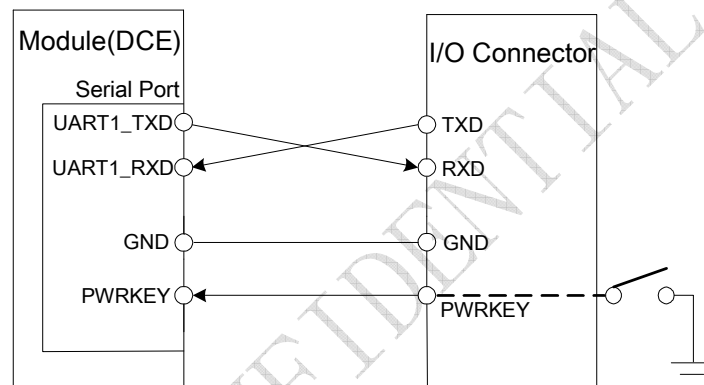
Pin	Min	Typ	Max	Unit
USB_VBUS	4.3	5.0	7.0	V

#### 4.5.4 Software Upgrade

Customer could upgrade module's firmware through USB or UART interface.

If upgrading through USB interface, it is necessary to power on SIM800C first, and then connect USB\_VBUS, USB\_DP, USB\_DN, and GND to PC. There is no need to operate PWRKEY pin in the whole procedure, when SIM800C detects USB\_VBUS and could communicate normally with USB\_DP and USB\_DN, it will enter USB download mode automatically.

If customer upgrades the software through UART interface, it is strongly recommended to lead the UART1\_TXD, UART1\_RXD, GND and PWRKEY pin to IO connector for the upgrading, and PWRKEY pin should connect to GND while upgrading. Refer to the following figure for debugging and upgrading software.



**Figure 24: Connection for software upgrading and debugging**

The UART interface supports the CMOS level. If customer connects the module to the computer, the level shifter should be added between the DCE and DTE.

#### 4.6. UART1\_RI Behaviors

**Table 11: RI behaviors**

State	RI response
Standby	High
Voice call	The pin is changed to low. When any of the following events occur, the pin will be changed to high: (1) Establish the call (2) Hang up the call
SMS	The pin is changed to low, and kept low for 120ms when a SMS is received. Then it is changed to high.
Others	For more details, please refer to <i>document [2]</i> .

The behavior of the RI pin is shown in the following figure when the module is used as a receiver.

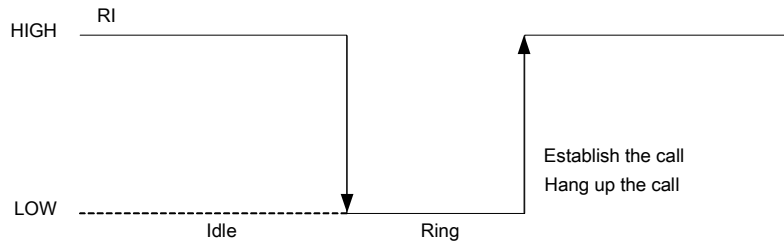


Figure 25: UART1\_RI behaviour of voice calling as a receiver

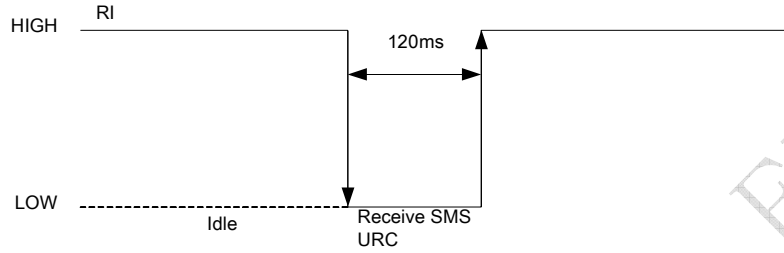


Figure 26: UART1\_RI behaviour of URC or receive SMS

However, if the module is used as caller, the UART1\_RI will remain high. Please refer to the following figure.

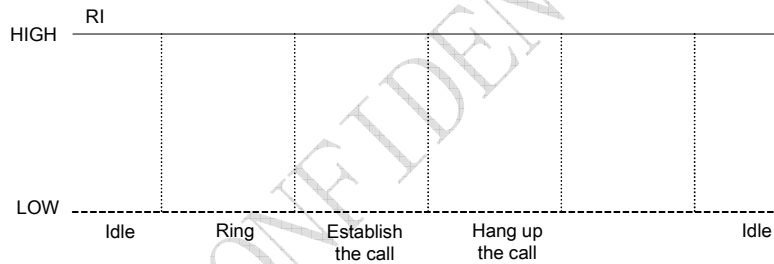


Figure 27: UART1\_RI behaviour as a caller

#### 4.7. Audio Interfaces

SIM800C provides an analog input (MICP; MICN), which could be used for electret microphone. The module also provides an analog output (SPKP; SPKN).

Table 12: Audio interface definition

Pin name	Pin number	Function
MICP	9	Audio input positive
MICN	10	Audio input negative
SPKP	11	Audio output positive
SPKN	12	Audio output negative

SPKP/SPKN output can directly drive 32Ω receiver.

AT command “AT+CMIC” is used to adjust the input gain level of microphone. AT command “AT+SIDET” is used to set the side-tone level. In addition, AT command “AT+CLVL” is used to adjust the output gain level. For more details, please refer to *document [1]*.

In order to improve audio performance, the following reference circuits are recommended. The audio signals have to be layout according to differential signal layout rules as shown in following figures.

### 4.7.1. Speaker Interfaces Configuration

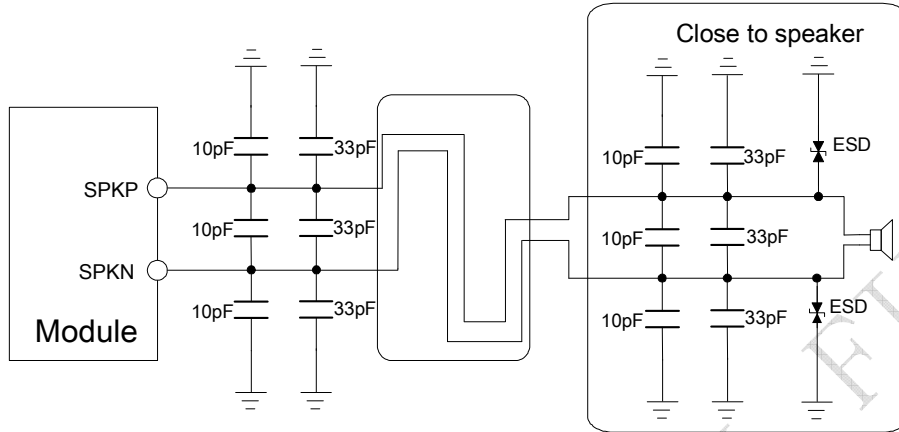


Figure 28: Speaker reference circuit

### 4.7.2. Microphone Interfaces Configuration

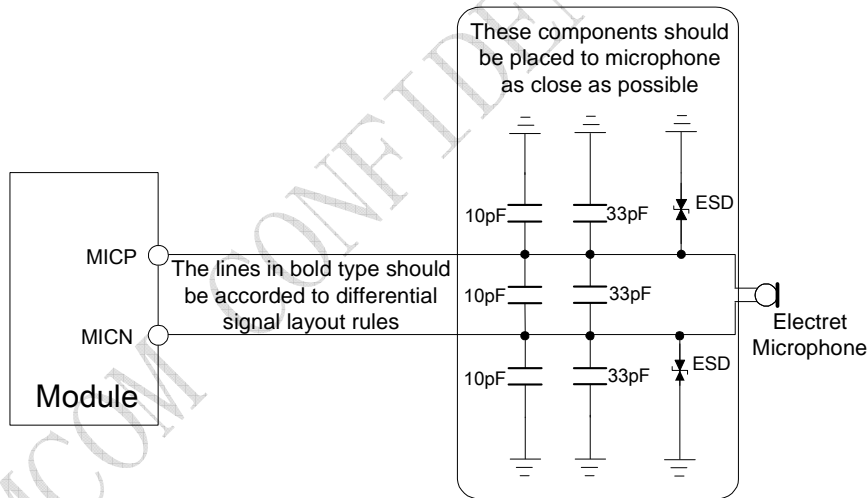


Figure 29: Microphone reference circuit

### 4.7.3. Audio Electronic Characteristic

Table 13: Microphone input characteristics

Parameter	Min	Typ	Max	Unit
Microphone biasing voltage	-	1.9	2.2	V
Working current	-	-	2.0	mA
Input impedance(differential)	13	20	27	KΩ
Idle channel noise	-	-	-67	dBm0
SINAD	Input level:-40dBm0	29	-	dB

Input level:0dBm0	-	69	-	dB
-------------------	---	----	---	----

**Table 14: Audio output characteristics**

Parameter	Conditions	Min	Typ	Max	Unit
Normal output	$R_L=32\ \Omega$ receiver	-	15	90	mW

#### 4.7.4. TDD

Audio signal could be interferenced by RF signal. Coupling noise could be filtered by adding 33pF and 10pF capacitor to audio lines. 33pF capacitor could eliminate noise from GSM850/EGSM900MHz, while 10pF capacitor could eliminate noise from DCS1800/PCS1900Mhz frequency. Customer should develop this filter solution according to field test result.

GSM antenna is the key coupling interfering source of TDD noise. Thereat, pay attention to the layout of audio lines which should be far away from RF cable, antenna and VBAT pin. The bypass capacitor for filtering should be placed near module and another group needs to be placed near to connector.

Conducting noise is mainly caused by the VBAT drop. If audio PA was powered by VBAT directly, then there will be some cheep noise from speaker output easily. So it is better to put big capacitors and ferrite beads near audio PA input.

TDD noise has something to do with GND signal. If GND plane is not good, lots of high-frequency noises will interference microphone and speaker over bypass capacitor. So a good GND during PCB layout could avoid TDD noise.

### 4.8. SIM Card Interface

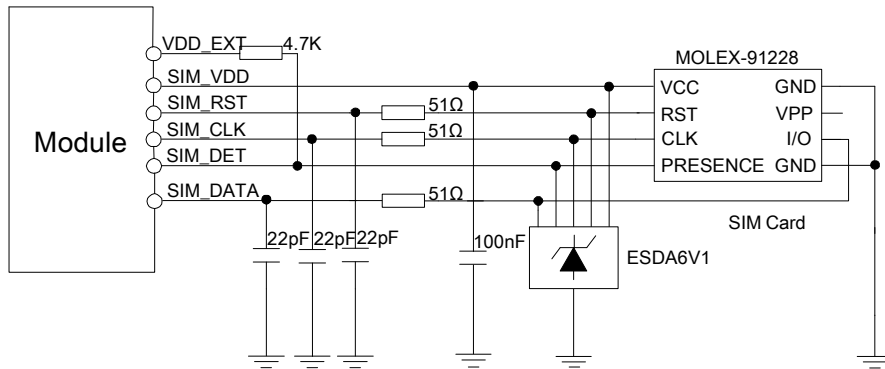
The SIM interface complies with the GSM Phase 1 specification and the new GSM Phase 2+ specification for FAST 64kbps SIM card. Both 1.8V and 3.0V SIM card are supported. The SIM interface is powered from an internal regulator in the module.

#### 4.8.1. SIM Card Application

**Table 15: SIM pin definition**

Pin name	Pin number	Function
SIM_VDD	18	Voltage supply for SIM card. Support 1.8V or 3V SIM card
SIM_DATA	15	SIM data input/output
SIM_CLK	16	SIM clock
SIM_RST	17	SIM reset
SIM_DET	14	SIM card detection

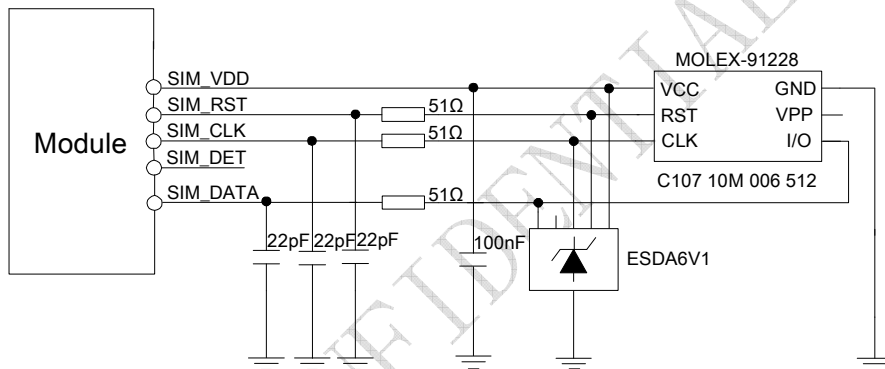
It is recommended to use an ESD protection component such as ST ([www.st.com](http://www.st.com)) ESDA6V1-5W6. The SIM card peripheral components should be placed close to the SIM card holder. The reference circuit of the 8-pin SIM card holder is illustrated in the following figure.



**Figure 30: Reference circuit of the 8-pin SIM card holder**

The SIM\_DET pin is used for detection of the SIM card hot plug in. Customer can select the 8-pin SIM card holder to implement SIM card detection function. AT command “AT+CSDT” is used to enable or disable SIM card detection function. For details of this AT command, please refer to *document [1]*.

If the SIM card detection function is not used, customer can keep the SIM\_DET pin open. The reference circuit of 6-pin SIM card holder is illustrated in the following figure.



**Figure 31: Reference circuit of the 6-pin SIM card holder**

#### 4.8.2. SIM Card Design Guide

SIM card signal could be interferenced by some high frequency signal, it is strongly recommended to follow these guidelines while designing:

- SIM card holder should be far away from GSM antenna
- SIM traces should keep away from RF lines, VBAT and high-speed signal lines
- The traces should be as short as possible
- Keep SIM card holder’s GND connect to main ground directly
- Shielding the SIM card signal by ground well
- Recommended to place a 100nF capacitor on SIM\_VDD line and keep close to the SIM card holder
- Add some TVS which parasitic capacitance should not exceed 50pF
- Add 51Ω resistor to (SIM\_RST/SIM\_CLK/SIM\_DATA) signal could enhance ESD protection
- Add 22pF capacitor to (SIM\_RST/SIM\_CLK/SIM\_DATA) signal to induce RF signal interference

#### 4.8.3. Design Considerations for SIM Card Holder

For 8 pins SIM card holder, SIMCom recommends to use Molex 91228. Customer can visit <http://www.molex.com> for more information about the holder.



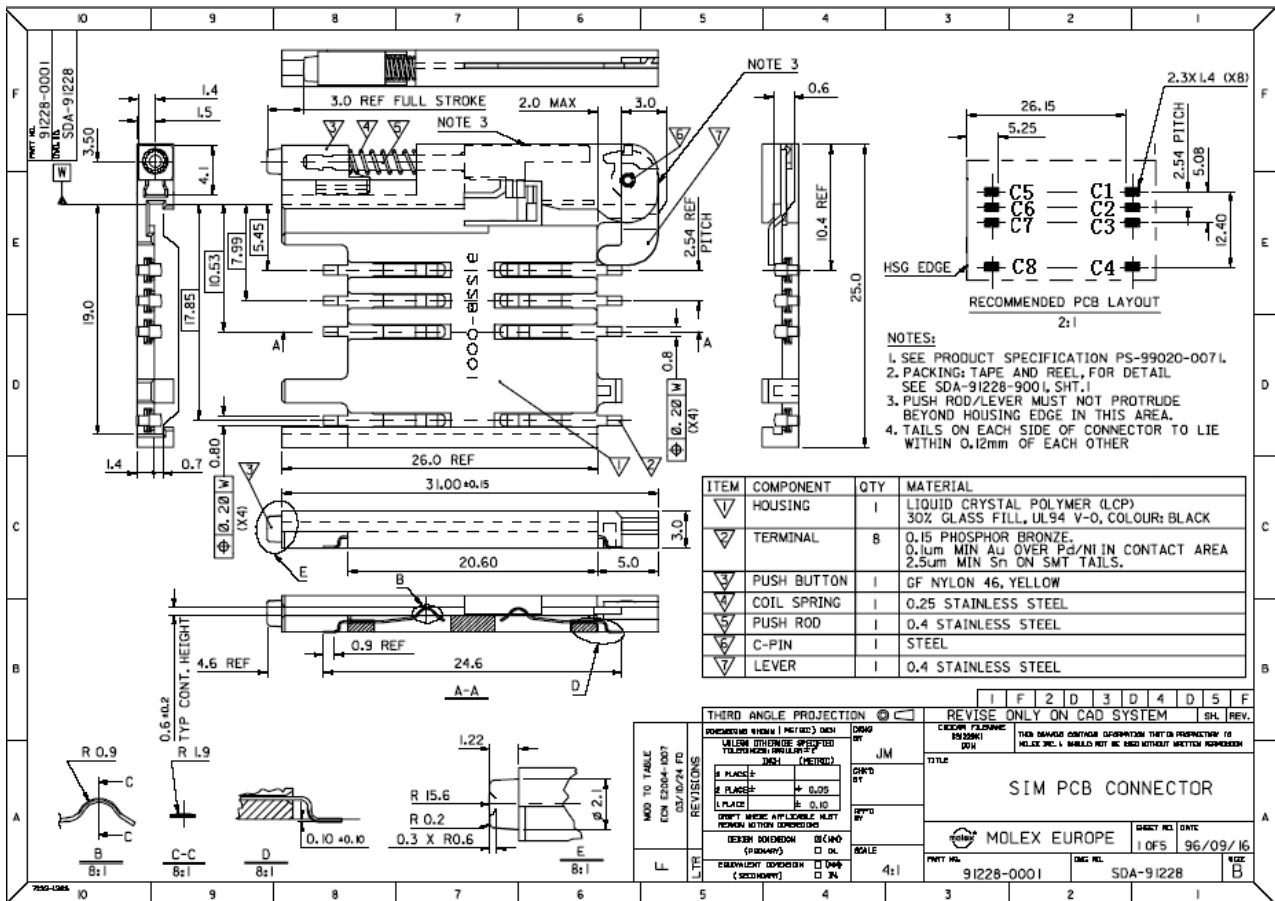


Figure 32: Molex 91228 SIM card holder

Table 16: Pin description (Molex SIM card holder)

Pin name	Signal	Description
C1	SIM_VDD	SIM card power supply
C2	SIM_RST	SIM card reset
C3	SIM_CLK	SIM card clock
C4	GND	Connect to GND
C5	GND	Connect to GND
C6	VPP	Not connect
C7	SIM_DATA	SIM card data I/O
C8	SIM_DET	Detect SIM card presence

For 6-pin SIM card holder, SIMCom recommends to use Amphenol C707 10M006 512 .Customer can visit <http://www.amphenol.com> for more information about the holder.

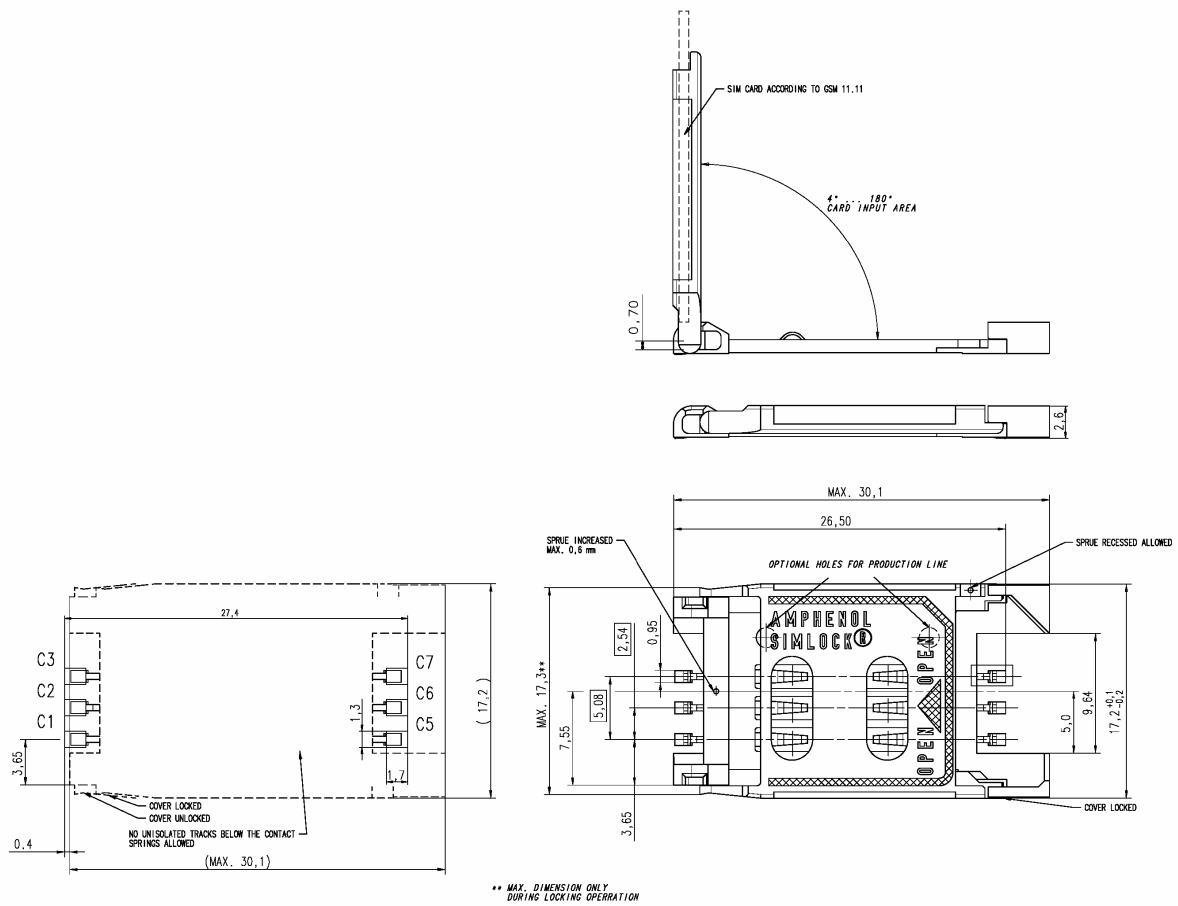


Figure 33: Amphenol C707 10M006 512 SIM card holder

Table 17: Pin description (Amphenol SIM card holder)

Pin name	Signal	Description
C1	SIM_VDD	SIM card power supply
C2	SIM_RST	SIM card reset
C3	SIM_CLK	SIM card clock
C5	GND	Connect to GND
C6	VPP	Not connect
C7	SIM_DATA	SIM card data I/O

Note: Every time plug SIM card interval advice is greater than 2s. Otherwise may not be able to correct detection.

#### 4.9. ADC

Table 18: Pin definition of the ADC

Pin name	Pin number	Description
ADC	38	Analog voltage input

SIM800C provides an auxiliary ADC, which can be used to measure the voltage. Customer can use AT command “AT+CADC” to read the voltage value. For details of this AT command, please refer to *document [1]*.

**Table 19: ADC specification**

Parameter	Min	Typ	Max	Unit
Voltage range	0	-	2.8	V
ADC Resolution	-	10	-	bits
Sampling rate	-	-	1.0833	MHz
ADC precision		10	30	mV

#### 4.10. Network Status Indication

**Table 20: Pin definition of the NETLIGHT**

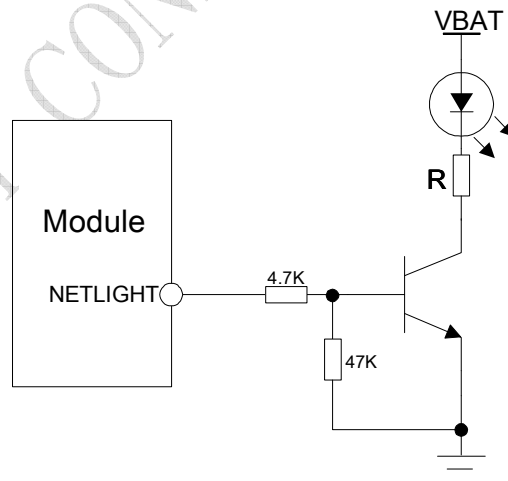
Pin name	Pin number	Description
NETLIGHT	41	Network Status Indication

The NETLIGHT pin can be used to drive a network status indication LED. The status of this pin is listed in following table:

**Table 21: Status of the NETLIGHT pin**

Status	SIM800C behavior
Off	Powered off
64ms On/ 800ms Off	Not registered the network
64ms On/ 3000ms Off	Registered to the network
64ms On/ 300ms Off	GPRS communication is established

Reference circuit is recommended in the following figure:


**Figure 34: Reference circuit of NETLIGHT**

##### 4.10.1. NETLIGHT Multiplexing Function

**Table 22: NETLIGHT multiplexing function**

Pin name	Pin number	Mode 0(default)	Mode 1
NETLIGHT	41	NETLIGHT	GPIO

*Note: Multiplexing function need different software supply.*

## 4.11. Operating Status Indication

The pin42 is for operating status indication of the module. The pin output is high when module is powered on, and output is low when module is powered off.

**Table 23: Pin definition of the STATUS**

Pin name	Pin number	Description
STATUS	42	Operating status indication

*Note: For timing about STATUS, please reference to the chapter “4.2 power on/down scenarios”*

### 4.11.1. STATUS Multiplexing Function

**Table 24: STATUS multiplexing function**

Pin name	Pin number	Mode 0(default)	Mode 1
STATUS	42	STATUS	GPIO

*Note: Multiplexing function need different software supply.*

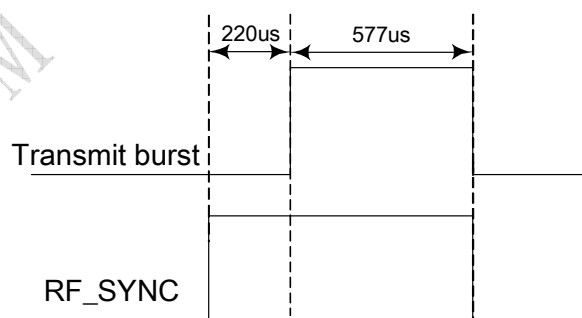
## 4.12. RF Synchronization Signal

The synchronization signal is used to indicate incoming GSM burst.

**Table 25: Definition of the RF\_SYNC pin**

Pin name	Pin number	Description
RF_SYNC	29	Transmit synchronization signal

The timing of the synchronization signal is shown below.



**Figure 35: RF\_SYNC signal during transmit burst**

### 4.12.1. RF\_SYNC Multiplexing Function

RF\_SYNC can also be used as GPIO to indicate the RF Jamming. The RF\_SYNC function and RF Jamming Detection function can be switched by AT+SJDR command.

**Table 26: RF\_SYNC Multiplexing function**

Pin name	Pin number	Mode 0(default)	Mode 1
RF_SYNC	29	RF Synchronization Signal	JD (RF jamming detection)

Note: About AT+SJDR, please refer to document [1].

### 4.13. Antenna Interface

There are two antenna interfaces, GSM\_ANT and BT\_ANT.

- The input impedance of the antenna should be 50Ω, and the VSWR should be less than 2.
- It is recommended that the GSM antenna and the BT antenna should be placed as far as possible.
- The isolations of the two antenna should be bigger than 30dB

NOTE: About the RF trace layout please refer to “AN\_SMT Module\_RF\_Reference\_Design\_Guide”.

#### 4.13.1 GSM Antenna Interface

SIM800C provides a GSM antenna named GSM\_ANT, customer could use 50Ω microstrip line or stripline antenna connect to the module.

It is recommended to reserve the matching circuit as following:

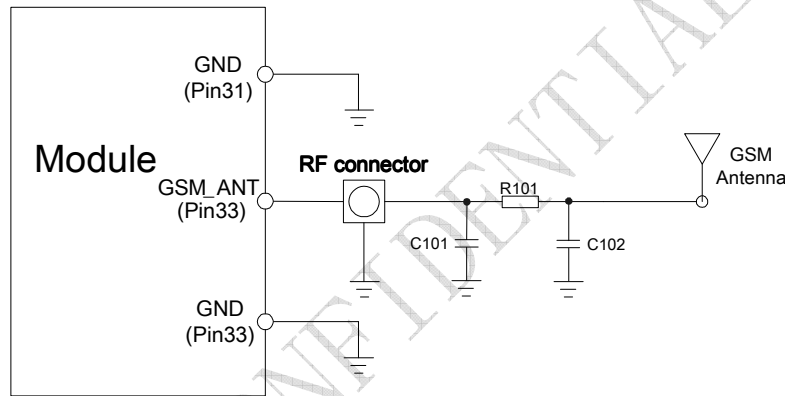


Figure 36: GSM antenna matching circuit

R101, C101, C102 are the matching circuit, the value should be defined by the antenna design. Normally R101 is 0Ω, C101 and C102 are not mounted.

The RF connector is used for conduction test. If the space between RF pin and antenna is not enough, the matching circuit should be designed as in the following figure:

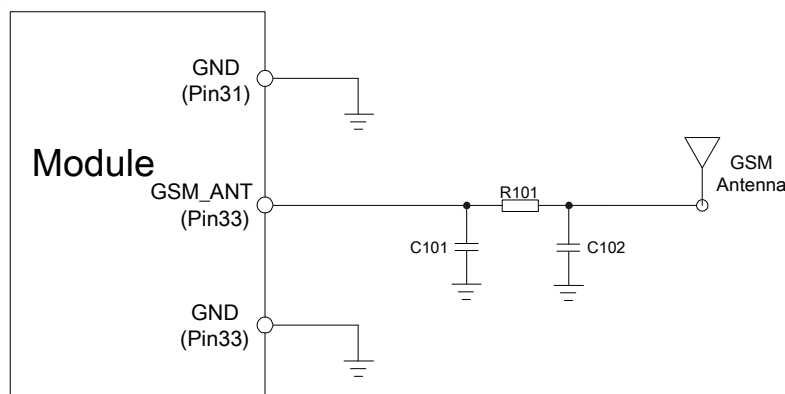
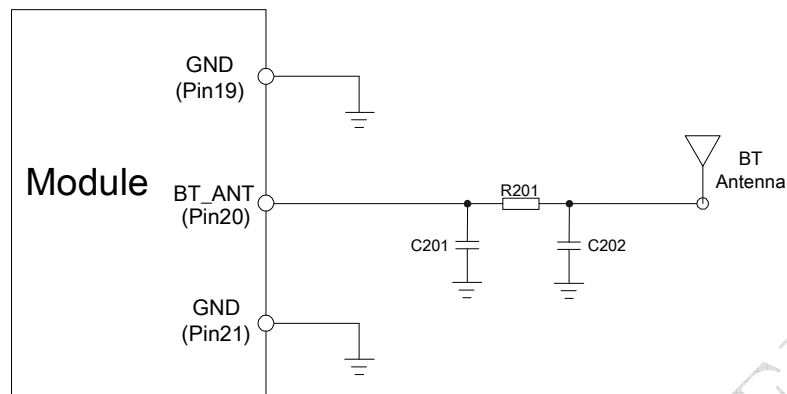


Figure 37: GSM antenna matching circuit without RF connector

Normally R101 is  $0\Omega$ , C101 and C102 are not mounted.

#### 4.13.2 Bluetooth Antenna Interface

It is recommended to reserve the matching circuit as following:



**Figure 38: Bluetooth antenna matching circuit**

R201, C201, C202 are the matching circuit, the value should be defined by the antenna design. Normally R201 is  $0\Omega$ , C202 and C201 are not mounted.

There are some suggestions for placing components and RF trace for GSM\_ANT/BT\_ANT:

- The RF connector is used for conducted test, so keep it as close to pin GSM\_ANT as possible;
- Antenna matching circuit should be close to the antenna;
- Keep the RF traces impedance as  $50\Omega$ ;
- The RF traces should be kept far away from the high frequency signals and strong interference source.

## 5. PCB Layout

This section will give some guidelines on PCB layout, in order to eliminate interfere or noise.

### 5.1 Pin Assignment

Before PCB layout, we should learn about pin assignment in order to get reasonable layout with so many external components. Following figure is the overview of pin assignment of the module.

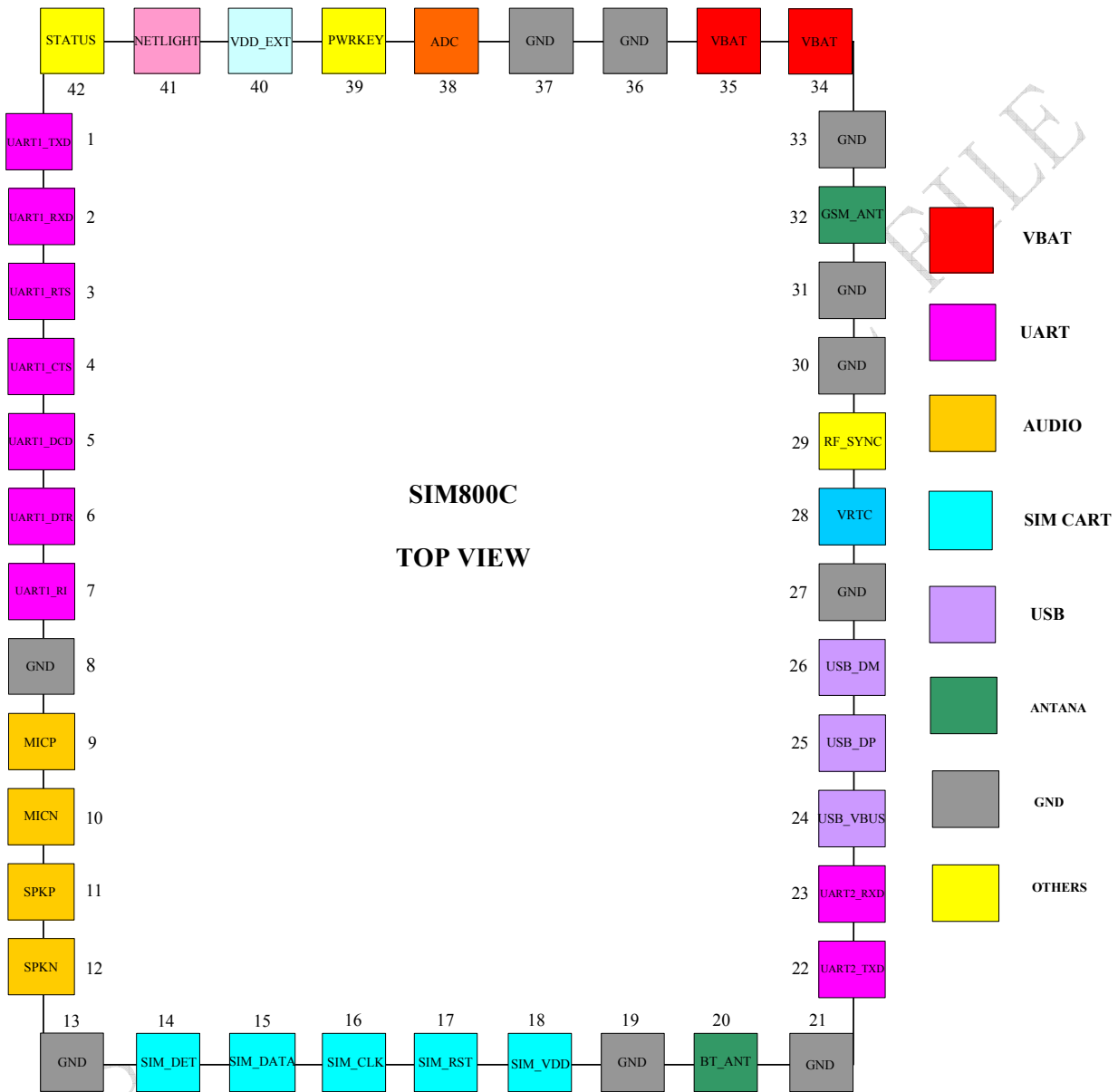


Figure 39: Pin assignment

### 5.2 Principle of PCB Layout

During layout, attention should be paid to the following interfaces, like Antenna, power supply, SIM card interface, audio interface, and so on.

### 5.2.1 Antenna Interface

- The length of trace between pin output and connector should be as short as possible;
- Do not trace RF signal over across the board;
- The RF signal should be far away from SIM card, power ICs.

### 5.2.2 Power Supply

- Not only VBAT but also return GND are very important in layout;
- The positive line of VBAT should be as short and wide as possible;
- The correct flow from source to VBAT pin should go though Zener diode then huge capacitor;
- Pin 36 and Pin37 are GND signals, and shortest layout to GND of power source should be designed;
- There are 10 GND pads in the module; these pads could enhance the GND performances. On the upper layer of these pads, do not trace any signal if possible.

### 5.2.3 SIM Card Interface

- SIM card holder has no anti-EMI component inside. Thus SIM card interface maybe interfered, please pay more attention on this interface during layout;
- Ensure SIM card holder is far way from antenna or RF cable inside;
- Put SIM card holder near the module, as nearer as possible;
- Add ESD component to protect SIM\_CLK, SIM\_DATA, SIM\_RST and SIM\_VDD signals which should be far away from power and high-speed-frequency signal.

### 5.2.4 Audio Interface

- The signal trace of audio should far away from antenna and power;
- The audio signal should avoid to parallel with VBAT trace.

### 5.2.5 Others

- It is better to trace signal lines of UART bunched, as well as signals of USB.



## 6. Electrical, Reliability and Radio Characteristics

### 6.1 Absolute Maximum Ratings

The absolute maximum ratings stated in following table are stress ratings under non-operating conditions. Stresses beyond any of these limits will cause permanent damage to SIM800C.

**Table 27: Absolute maximum ratings**

Symbol	Min	Typ	Max	Unit
VBAT	-	-	4.5	V
Current	0	-	2.0	A
USB_VBUS	-	-	12	V
I <sub>I</sub> *	-	4	16	mA
I <sub>O</sub> *	-	4	16	mA

\*These parameters are for digital interface pins, GPIO, and UART.

### 6.2 Recommended Operating Conditions

**Table 28: Recommended operating conditions**

Symbol	Parameter	Min	Typ	Max	Unit
VBAT	Power supply voltage	3.4	4.0	4.4	V
T <sub>OPER</sub>	Operating temperature	-40	+25	+85	°C
T <sub>STG</sub>	Storage temperature	-45		+90	°C

### 6.3 Digital Interface Characteristics

**Table 29: Digital interface characteristics**

Symbol	Parameter	Min	Typ	Max	Unit
V <sub>IH</sub>	High-level input current	2.1	-	3.1	V
V <sub>IL</sub>	Low-level input current	-0.3	-	0.7	V
V <sub>OH</sub>	High-level output voltage	2.4	-	-	V
V <sub>OL</sub>	Low-level output voltage	-	-	0.4	V

*Note: These parameters are for digital interface pins, such as keypad, GPIO and UART.*

### 6.4 SIM Card Interface Characteristics

**Table 30: SIM card interface characteristics**

Symbol	Parameter	Min	Typ	Max	Unit
I <sub>IH</sub>	High-level input current	-1.0	-	1.0	uA
I <sub>IL</sub>	Low-level input current	-1.0	-	1.0	uA

$V_{IH}$	High-level input voltage	1.4	-	-	V
		2.4	-	-	V
$V_{IL}$	Low-level input voltage	-	-	0.27	V
				0.4	V
$V_{OH}$	High-level output voltage	1.62	-	-	V
		2.7	-	-	V
$V_{OL}$	Low-level output voltage	-	-	0.36	V
		-	-	0.4	V

## 6.5 SIM\_VDD Characteristics

Table 31: SIM\_VDD characteristics

Symbol	Parameter	Min	Typ	Max	Unit
$V_O$	Output voltage	-	3.0	-	V
		-	1.8	-	
$I_O$	Output current	-	-	10	mA

## 6.6 VDD\_EXT Characteristics

Table 32: VDD\_EXT characteristics

Symbol	Parameter	Min	Typ	Max	Unit
$V_O$	Output voltage	2.7	2.8	2.9	V
$I_O$	Output current	-	-	50	mA

## 6.7 VRTC Characteristics

Table 33: VRTC characteristics

Symbol	Description	Min	Typ	Max	Unit
$V_{RTC-IN}$	VRTC input voltage	1.2	2.8	3.0	V
$I_{RTC-IN}$	VRTC input current	-	3.0	5.0	$\mu$ A
$V_{RTC-OUT}$	VRTC output voltage	-	2.8	-	V
$I_{RTC-OUT}$	VRTC output current	-		2.0	mA

## 6.8 Current Consumption (VBAT=4.0V)

Table 34: Current consumption

Symbol	Parameter	Conditions	Min	Typ	Max	Unit
VBAT	Voltage			4.0		V
	Power drop	PCL=5			350	mV
	Voltage ripple	PCL=5 @ f<200kHz			50	mV

		@ f>200kHzss			2.0	mV		
I <sub>VBAT</sub>	Average current	Power off mode		130	150	uA		
		Sleep mode (AT+CFUN=1): ( BS-PA-MFRMS=9 ) ( BS-PA-MFRMS=5 ) ( BS-PA-MFRMS=2 )		0.9 1 1.5		mA mA mA		
		Idle mode (AT+CFUN=1): GSM850 EGSM900 DCS1800 PCS1900		12.5 12.5 12.5 12.5		mA mA mA mA		
		Voice call (PCL=5): GSM850 EGSM900 Voice call (PCL=0): DCS1800 PCS1900		209 211 123 143		mA mA mA mA		
		Data mode GPRS (1Rx,4Tx): GSM850 EGSM900 DCS1800 PCS1900		385 389 270 285		mA mA mA mA		
		Data mode GPRS (3Rx,2Tx): GSM850 EGSM900 DCS1800 PCS1900		326 340 208 228		mA mA mA mA		
		Data mode GPRS (4Rx,1Tx): GSM850 EGSM900 DCS1800 PCS1900		218 228 146 162		mA mA mA mA		
		I <sub>MAX</sub>	Peak current	During Tx burst			2.0	A

*Note: In above table the current consumption value is the typical one of the module tested in laboratory. In the mass production stage, there may be differences among each individual.*

## 6.9 Electro-Static Discharge

SIM800C is an ESD sensitive component, so attention should be paid to the procedure of handling and packaging. The ESD test results are shown in the following table.

**Table 35: The ESD characteristics (Temperature: 25°C, Humidity: 45 %)**

Pin name	Contact discharge	Air discharge
VBAT	±5KV	±12KV

GND	±6KV	±12KV
UART1_TXD /UART1_RXD	±4KV	±8KV
Antenna port	±5KV	±10KV
SPKP/SPKN/MICP/MICN	±4KV	±8KV
PWRKEY	±4KV	±8KV

## 6.10 Radio Characteristics

### 6.10.1 Module RF Output Power

The following table shows the module conducted output power, it is followed by the 3GPP TS 05.05 technical specification requirement.

**Table 36: GSM850 and EGSM900 conducted RF output power**

GSM850,EGSM900			
PCL	Nominal output power (dBm)	Tolerance (dB) for conditions	
		Normal	Extreme
5	33	±2	±2.5
6	31	±3	±4
7	29	±3	±4
8	27	±3	±4
9	25	±3	±4
10	23	±3	±4
11	21	±3	±4
12	19	±3	±4
13	17	±3	±4
14	15	±3	±4
15	13	±3	±4
16	11	±5	±6
17	9	±5	±6
18	7	±5	±6
19-31	5	±5	±6

**Table 37: DCS1800 and PCS1900 conducted RF output power**

DCS1800,PCS1900			
PCL	Nominal output power (dBm)	Tolerance (dB) for conditions	
		Normal	Extreme
0	30	±2	±2.5
1	28	±3	±4
2	26	±3	±4
3	24	±3	±4

4	22	±3	±4
5	20	±3	±4
6	18	±3	±4
7	16	±3	±4
8	14	±3	±4
9	12	±4	±5
10	10	±4	±5
11	8	±4	±5
12	6	±4	±5
13	4	±4	±5
14	2	±5	±6
15	0	±5	±6

### 6.10.2 Module RF Receive Sensitivity

The following table shows the module's conducted receiving sensitivity, it is tested under static condition.

**Table 38: Conducted RF receive sensitivity**

Frequency	Receive sensitivity (Typical)	Receive sensitivity(Max)
GSM850,EGSM900	< -109dBm	< -107dBm
DCS1800,PCS1900	< -109dBm	< -107dBm

### 6.10.3 Module Operating Frequencies

The following table shows the module's operating frequency range; it is followed by the 3GPP TS 05.05 technical specification requirement.

**Table 39: Operating frequencies**

Frequency	Receive	Transmit
GSM850	869 ~ 894MHz	824 ~ 849MHz
EGSM900	925 ~ 960MHz	880 ~ 915MHz
DCS1800	1805 ~ 1880MHz	1710 ~ 1785MHz
PCS1900	1930 ~ 1990MHz	1850 ~ 1910MHz

## 7. Manufacturing

### 7.1. Top and Bottom View of SIM800C

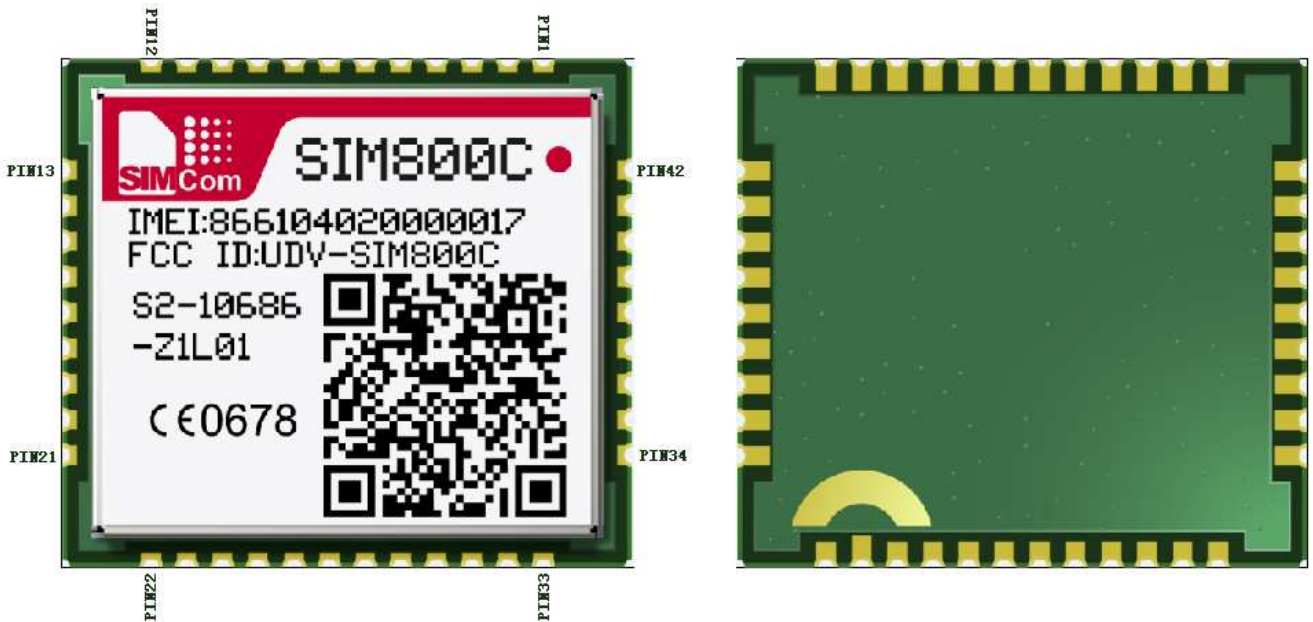


Figure 40: Top and bottom view of SIM800C

### 7.2. Typical Solder Reflow Profile

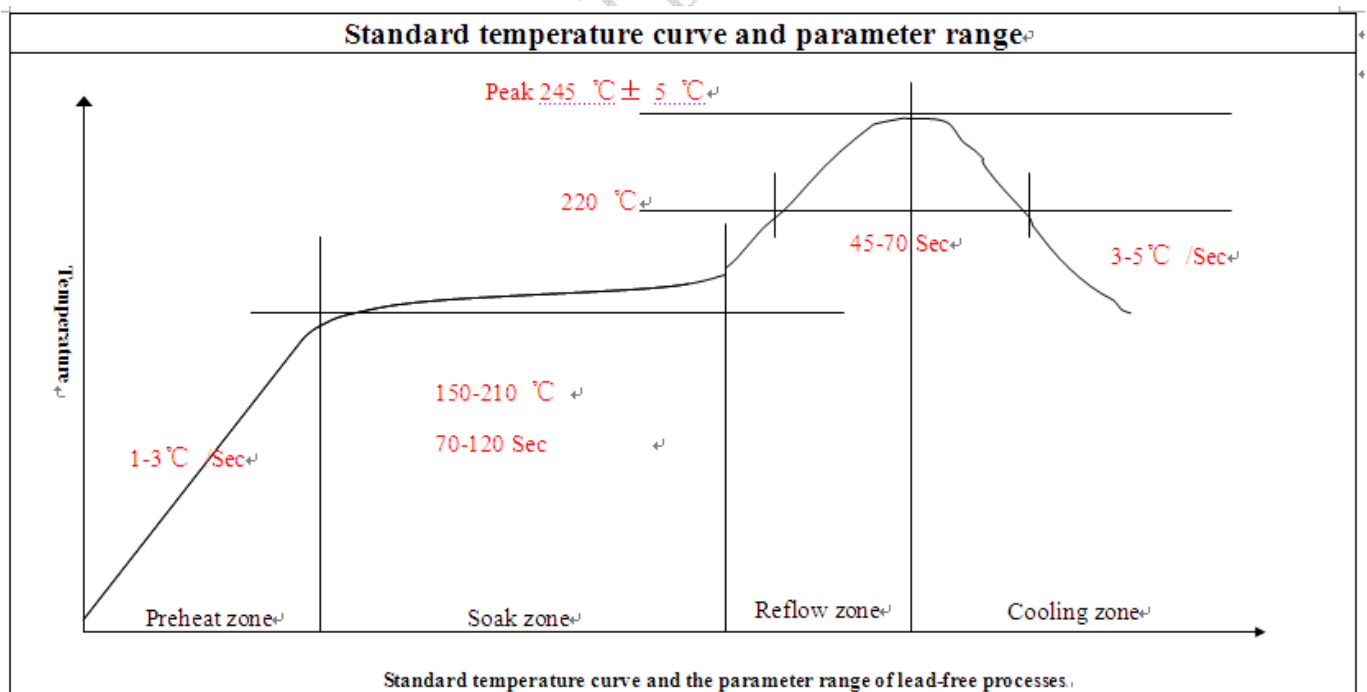


Figure 41: Typical solder reflow profile of lead-free processes

### 7.3. The Moisture Sensitivity Level

The moisture sensitivity level of SIM800C module is 3. The modules should be mounted within 168 hours after unpacking in the environmental conditions of temperature  $<30^{\circ}\text{C}$  and relative humidity of  $<60\%$  (RH). It is necessary to bake the module if the above conditions are not met:

**Table 40: Moisture sensitivity level and floor life**

Moisture Sensitivity Level (MSL)	Floor Life (out of bag) at factory ambient $\leq 30^{\circ}\text{C}/60\%$ RH or as stated
1	Unlimited at $\leq 30^{\circ}\text{C}/85\%$ RH
2	1 year
2a	4 weeks
3	168 hours
4	72 hours
5	48 hours
5a	24 hours
6	Mandatory bake before use. After bake, it must be reflowed within the time limit specified on the label.

**NOTES:**

*For product handling, storage, processing, IPC / JEDEC J-STD-033 must be followed.*

**7.4. Baking Requirements**

SIM800C modules are vacuum packaged, and guaranteed for 6 months storage without opening or leakage under the following conditions: the environment temperature is lower than  $40^{\circ}\text{C}$ , and the air humidity is less than 90%.

If the condition meets one of the following ones shown below, the modules should be baked sufficiently before re-flow soldering, and the baking condition is shown in below table; otherwise the module will be at the risk of permanent damage during re-flow soldering.

- If the vacuum package is broken or leakage;
- If the vacuum package is opened after 6 months since it's been packed;
- If the vacuum package is opened within 6 months but out of its Floor Life at factory ambient  $\leq 30^{\circ}\text{C}/60\%$  RH or as stated.

**Table 41: Baking requirements**

Baking temperature	Moisture	Time
$40^{\circ}\text{C} \pm 5^{\circ}\text{C}$	$<5\%$	192 hours
$120^{\circ}\text{C} \pm 5^{\circ}\text{C}$	$<5\%$	6 hours

*Note: Care should be taken if that plastic tray is not heat-resistant, the modules should be taken out for preheating, otherwise the tray may be damaged by high-temperature heating.*

## 8. Appendix

### I. Related Documents

**Table 42: Related documents**

SN	Document name	Remark
[1]	SIM800 Series AT Command Manual	
[2]	SIM800 Series Port Application Note_V1 02.doc	
[3]	ITU-T Draft new recommendation V.25ter:	Serial asynchronous automatic dialing and control
[4]	GSM 07.07:	Digital cellular telecommunications (Phase 2+); AT command set for GSM Mobile Equipment (ME)
[5]	GSM 07.10:	Support GSM 07.10 multiplexing protocol
[6]	GSM 07.05:	Digital cellular telecommunications (Phase 2+); Use of Data Terminal Equipment – Data Circuit terminating Equipment (DTE – DCE) interface for Short Message Service (SMS) and Cell Broadcast Service (CBS)
[7]	GSM 11.14:	Digital cellular telecommunications system (Phase 2+); Specification of the SIM Application Toolkit for the Subscriber Identity Module – Mobile Equipment (SIM – ME) interface
[8]	GSM 11.11:	Digital cellular telecommunications system (Phase 2+); Specification of the Subscriber Identity Module – Mobile Equipment (SIM – ME) interface
[9]	GSM 03.38:	Digital cellular telecommunications system (Phase 2+); Alphabets and language-specific information
[10]	GSM 11.10	Digital cellular telecommunications system (Phase 2); Mobile Station (MS) conformance specification; Part 1: Conformance specification
[11]	AN_Serial Port	AN_Serial Port



## II. Multiplexing Function

**Table 43: Multiplexing function**

Pin name	Reset	Pin number	Mode 0(default)	Mode 1	Mode 2	Mode 3
STATUS	I/PD	42	STATUS	GPIO19	-	
SIM_DET	I/PD	14	SIM_DET	GPIO20	EINT14	
NETLIGHT	I/PD	41	NETLIGHT	GPIO17	UTXD3	
UART1_DTR	I/PD	6	UART1_DTR	GPIO18	EINT13	
UART1_RI	I/PD	7	UART1_RI	GPIO13	EINT11	
UART1_DCD	I/PD	5	UART1_DCD	GPIO12	URXD3	
UART1_CTS	I/PD	4	UART1_CTS	GPIO14	EINT12	
UART1_RTS	I/PD	3	UART1_RTS	GPIO15		
UART1_TXD	HO	1	UART1_TXD	GPIO11		
UART1_RXD	I/PD	2	UART1_RXD	GPIO10		
UART2_TXD	HO	22	UART3_TXD	GPIO0		
UART2_RXD	I/PD	23	UART3_RXD	GPIO1		

*Note: Multiplexing function need different software supply.*

## III. Terms and Abbreviations







**Table 44: Terms and abbreviations**

Abbreviation	Description
ADC	Analog-to-Digital Converter
AMR	Adaptive Multi-Rate
CS	Coding Scheme
CTS	Clear to Send
DTE	Data Terminal Equipment (typically computer, terminal, printer)
DTR	Data Terminal Ready
DTX	Discontinuous Transmission
EFR	Enhanced Full Rate
EGSM	Enhanced GSM
ESD	Electrostatic Discharge
ETS	European Telecommunication Standard
FR	Full Rate
GPRS	General Packet Radio Service
GSM	Global Standard for Mobile Communications
HR	Half Rate
MO	Mobile Originated
MS	Mobile Station (GSM engine), also referred to as TE
MT	Mobile Terminated
PAP	Password Authentication Protocol

PBCCH	Packet Broadcast Control Channel
PCB	Printed Circuit Board
PCL	Power Control Level
PCS	Personal Communication System, also referred to as GSM 1900
PDU	Protocol Data Unit
PPP	Point-to-point protocol
RF	Radio Frequency
RMS	Root Mean Square (value)
RX	Receive Direction
SIM	Subscriber Identification Module
SMS	Short Message Service
TE	Terminal Equipment, also referred to as DTE
TX	Transmit Direction
SINAD	Signal to Noise and Distortion Ratio
UART	Universal Asynchronous Receiver & Transmitter
URC	Unsolicited Result Code
USSD	Unstructured Supplementary Service Data
<b>Phonebook abbreviations</b>	
FD	SIM fix dialing phonebook
LD	SIM last dialing phonebook (list of numbers most recently dialed)
MC	Mobile Equipment list of unanswered MT calls (missed calls)
ON	SIM (or ME) own numbers (MSISDNs) list
RC	Mobile Equipment list of received calls
SM	SIM phonebook
NC	Not connect

## IV. Safety Caution

**Table 45: Safety caution**

Marks	Requirements
	When in a hospital or other health care facility, observe the restrictions about the use of mobiles. Switch the cellular terminal or mobile off, medical equipment may be sensitive to not operate normally for RF energy interference.
	Switch off the cellular terminal or mobile before boarding an aircraft. Make sure it is switched off. The operation of wireless appliances in an aircraft is forbidden to prevent interference with communication systems. Forget to think much of these instructions may lead to the flight safety or offend against local legal action, or both.
	Do not operate the cellular terminal or mobile in the presence of flammable gases or fumes. Switch off the cellular terminal when you are near petrol stations, fuel depots, chemical plants or where blasting operations are in progress. Operation of any electrical equipment in potentially explosive atmospheres can constitute a safety hazard.
	Your cellular terminal or mobile receives and transmits radio frequency energy while switched on. RF interference can occur if it is used close to TV sets, radios, computers or other electric equipment.
	Road safety comes first! Do not use a hand-held cellular terminal or mobile when driving a vehicle, unless it is securely mounted in a holder for hands free operation. Before making a call with a hand-held terminal or mobile, park the vehicle.
	<p>GSM cellular terminals or mobiles operate over radio frequency signals and cellular networks and cannot be guaranteed to connect in all conditions, for example no mobile fee or a invalid SIM card. While you are in this condition and need emergent help, please remember using emergency calls. In order to make or receive calls, the cellular terminal or mobile must be switched on and in a service area with adequate cellular signal strength.</p> <p>Some networks do not allow for emergency call if certain network services or phone features are in use (e.g. lock functions, fixed dialing etc.). You may have to deactivate those features before you can make an emergency call.</p> <p>Also, some networks require that a valid SIM card be properly inserted in the cellular terminal or mobile.</p>

**Contact us:**

**Shanghai SIMCom Wireless Solutions Co.,Ltd.**

Address: Building A, SIM Technology Building, No. 633, Jinzhong Road, Shanghai, P. R. China  
200335

Tel: +86 21 3252 3300

Fax: +86 21 3252 3020

URL: [www.sim.com/wm](http://www.sim.com/wm)

SIMCOM CONFIDENTIAL FILE